

General Specifications

OpreX™ Pressure Transmitter EJX110S Differential Pressure Transmitter

GS 01C33C10-01EN

OVERVIEW

The high performance differential pressure transmitter EJX110S features single crystal silicon resonant sensor and is suitable to measure liquid, gas, or steam flow as well as liquid level, density and pressure. EJX110S outputs a 4 to 20 mA DC signal corresponding to the measured differential pressure. Its highly accurate and stable sensor can also measure the static pressure which can be shown on the integral indicator or remotely monitored via HART or PROFINET communications.

Other key features include quick response, backlit Graphic display,

EJX S series are certified as complying with SIL 2 for safety requirement.



STANDARD SPECIFICATIONS

Span and Range Limits

Capsule Range Code	Optional Code	kPa		inH ₂ O (/D1)		mbar (/D3)		mmH ₂ O (/D4)	
		Range	Span	Range	Span	Range	Span	Range	Span
Draft Range - Low Working Pressure (Up to 50 kPa)									
E	-	-1 to 1	0.025 to 1 (0.1 to 1)	-4 to 4	0.1 to 4 (0.4 to 4)	-10 to 10	0.25 to 10 (1 to 10)	-101 to 101	2.5 to 101 (10 to 101)
Standard Working pressure (Up to 25 MPa)									
F	-	-5 to 5	0.1 to 5	-20 to 20	0.4 to 20	-50 to 50	1 to 50	-509 to 509	10 to 509
M	-	-100 to 100	0.5 to 100	-401 to 401	2 to 401	-1000 to 1000	5 to 1000	-10197 to 10197	50 to 10197
	/CR1	-100 to 100	0.25 to 100	-401 to 401	1 to 401	-1000 to 1000	2.5 to 1000	-10197 to 10197	25 to 10197
H	-	-500 to 500	2.5 to 500	-2009 to 2009	10 to 2009	-5000 to 5000	25 to 5000	-5 to 5 kgf/cm ²	0.025 to 5 kgf/cm ²
	/CR2	-500 to 500	1.25 to 500	-2009 to 2009	5 to 2009	-5000 to 5000	12.5 to 5000	-5 to 5 kgf/cm ²	0.0125 to 5 kgf/cm ²
V	-	-0.5 to 14 MPa	0.07 to 14 MPa	-72 to 2030 psi	10 to 2030 psi	-5 to 140 bar	0.7 to 140 bar	-5 to 142 kgf/cm ²	0.7 to 142 kgf/cm ²
High Working Pressures Type (Over 25 MPa - Refer to limits)									
1	-	-100 to 100	1 to 100	-401 to 401	4 to 401	-1000 to 1000	10 to 1000	-10197 to 10197	101 to 10197
2	-	-500 to 500	5 to 500	-2009 to 2009	20 to 2009	-5000 to 5000	50 to 5000	-5 to 5 kgf/cm ²	0.05 to 5 kgf/cm ²
3	-	-0.5 to 14 MPa	0.14 to 14 MPa	-72 to 2030 psi	20 to 2030 psi	-5 to 140 bar	1.4 to 140 bar	-5 to 142 kgf/cm ²	1.4 to 142 kgf/cm ²

() show the span limits for square root output.

□ **Pressure limits**

EJX110S	Capsule range code	Maximum Over Pressure	Burst Pressure Limits
Wetted Parts Material code: S, L	E	50 kPa (7.25 psi)	-
	F	16 MPa (2300 psi)	47 MPa (6800 psi)
	M, H, V	25 MPa (3600 psi)	69 MPa (10000 psi)
Wetted Parts Material code: S	1	bolts and nuts material code D, F, L: 32 MPa (4500 psi) H, K: 41.3 MPa (6000 psi)	132 MPa (19100 psi)
	2		
	3		

□ **Performance Specifications**

Zero-based calibrated span, linear output, wetted parts material code “S” and silicone oil, unless otherwise mentioned.

Specification Conformance:

EJX S series ensures specification conformance to at least $\pm 3\sigma$

Reference Accuracy of Calibrated Span:

These specifications include terminal-based linearity, hysteresis, and repeatability.

Capsule Range Code	Optional Code	Reference Accuracy		X	URL (Upper Range Limit)	
		Span \geq X	Span<X			
Draft Range - Low Working Pressure (50 kPa)						
E	-	$\pm 0.09\%$	$\pm(0.015+0.03 \text{ URL}/\text{span})\%$	0.4 kPa (1.6 inH ₂ O)	1 kPa (4 inH ₂ O)	
Standard Working pressure (Up to 25 MPa)						
F	-	$\pm 0.04\%$	$\pm(0.015+0.01 \text{ URL}/\text{span})\%$	2 kPa (8 inH ₂ O)	5 kPa (20 inH ₂ O)	
M			$\pm(0.00175 \text{ URL}/\text{span})\%$	5 kPa (20 inH ₂ O)	100 kPa (401 inH ₂ O)	
H			$\pm 0.035\%$	$\pm(0.0049 \text{ URL}/\text{span})\%$	70 kPa (281 inH ₂ O)	500 kPa (2009 inH ₂ O)
V				$\pm(0.00125 \text{ URL}/\text{span})\%$	500 kPa (72 psi)	14 MPa (2030 psi)
M	/HAC	$\pm 0.025\%$	$\pm(0.015+0.001 \text{ URL}/\text{span})\%$	10 kPa (40 inH ₂ O)	100 kPa (401 inH ₂ O)	
H			$\pm(0.0035 \text{ URL}/\text{span})\%$	70 kPa (281 inH ₂ O)	500 kPa (2009 inH ₂ O)	
V			$\pm(0.004+0.00075 \text{ URL}/\text{span})\%$	500 kPa (72 psi)	14 MPa (2030 psi)	
High Working Pressures Type (Over 25 MPa - Refer to limits)						
1	-	$\pm 0.035\%$	$\pm(0.0035 \text{ URL}/\text{span})\%$	10 kPa (40 inH ₂ O)	100 kPa (401 inH ₂ O)	
2			$\pm(0.0049 \text{ URL}/\text{span})\%$	70 kPa (281 inH ₂ O)	500 kPa (2009 inH ₂ O)	
3			$\pm(0.00125 \text{ URL}/\text{span})\%$	500 kPa (72 psi)	14 MPa (2030 psi)	

Square Root Output Accuracy:

The square root accuracy is a percent of flow span.

Output	Accuracy
50% or Greater	Same as reference accuracy
50% to Dropout point	$\frac{\text{Reference accuracy} \times 50}{\text{Square root output (\%)}}$

Ambient Temperature Effects per 28°C (50°F) Change:

Capsule	Effect
E	$\pm(0.1\% \text{ Span} + 0.15\% \text{ URL})$
F	$\pm(0.055\% \text{ Span} + 0.18\% \text{ URL})$
M	$\pm(0.04\% \text{ Span} + 0.009\% \text{ URL})$
H	$\pm(0.04\% \text{ Span} + 0.0125\% \text{ URL})$
V	$\pm(0.04\% \text{ Span} + 0.0125\% \text{ URL})$
1	$\pm(0.07\% \text{ Span} + 0.009\% \text{ URL})$
2	$\pm(0.07\% \text{ Span} + 0.0125\% \text{ URL})$
3	$\pm(0.04\% \text{ Span} + 0.0125\% \text{ URL})$

Static Pressure Effects per 6.9 MPa (1000 psi) Change:

 $\pm 0.075\%$ of span

<Effect on Zero>

Capsule	Effect
M	$\pm 0.02\% \text{ URL}$
H, V	$\pm 0.028\% \text{ URL}$
1	$\pm 0.02\% \text{ URL}$
2, 3	$\pm 0.028\% \text{ URL}$

Overpressure Effects

Overpressure condition: up to maximum working pressure.

Capsule range code M, H: $\pm 0.03\%$

For Capsule range code 1, 2, 3 and Bolts and nuts material code D, F, L: $\pm 0.03\%$ of URL

For Capsule range code 1, 2, 3 and Bolts and nuts material code H, K: $\pm 0.04\%$ of URL

Stability (All normal operating condition, including overpressure effects):

$\pm 0.1\%$ of URL per 20 years: For Capsule range code M, H, V, 1, 2, 3 and Wetted material code S, L

$\pm 0.15\%$ of URL per 1 years: For Capsule range code E

$\pm 0.1\%$ of URL per 1 years: For Capsule range code F

Power Supply Effects: For HART Communication:

$\pm 0.005\%$ per Volt (from 21.6 to 32 V DC, 350Ω)

Vibration Effects:

Less than 0.1% of URL (10-60 Hz, 0.21 mm displacement/60-2000 Hz 3 G)

Mounting Position Effects:

Rotation in diaphragm plane has no effect. Tilting up to 90 degrees will cause zero shift up to 0.4 kPa (1.6 inH₂O) which can be corrected by the zero adjustment.

Total Probable Error (M capsule)

Total probable error, known as a measure of the total performance of the transmitters under the condition of fixed line pressure.

±0.12% of Span @1:1 to 5:1 Rangedown

$$\text{Total Probable Error} = \pm\sqrt{E_1^2 + E_2^2 + E_3^2}$$

- E1: Reference Accuracy of Calibrated Span
- E2: Ambient Temperature Effects per 28°C change
- E3: Static Span Effects per 6.9 MPa change

Total Accuracy (M capsule)

Total accuracy is a comprehensive measure of transmitter total performance, covering all major factors in actual installation, that cause errors in measurement.

As a standard measure, YOKOGAWA uses this to evaluate transmitter performance.

Not only a day-to-day changes in temperature can affect the measurement and lead to unnoticed errors; fluctuation of line pressure, incorrect operation of three/five valve manifold leading to over-pressure events, and other phenomena can have the similar result.

Total Accuracy factors in such changes and errors and provides much comprehensive and practical determination of how a transmitter will perform under actual plant operation.

±0.12% of Span @1:1 Rangedown

±0.25% of Span @5:1 Rangedown

$$\text{Total Accuracy} = \pm\sqrt{E_1^2 + E_2^2 + (E_3 + E_4)^2 + E_5^2}$$

- E1: Reference Accuracy of Calibrated Span
- E2: Ambient Temperature Effects per 28°C change
- E3: Static Span Effects per 6.9 MPa change
- E4: Static Zero Effects per 6.9 MPa change
- E5: Overpressure Effects up to overpressure 25 MPa

□ **Static Pressure Signal Range and Accuracy**

(For monitoring via communication or on indicator. Includes terminal-based linearity, hysteresis, and repeatability).

Range:

- For Capsule range code M, H, V

	Configurable span	Available range
Gauge pressure	0.5 to 25 MPa	-0.1 to 25 MPa
Absolute pressure	0.5 to 25 MPa	0 to 25 MPa abs

- For Capsule range code 1, 2, 3 and Bolts and nuts material code D, F, L

	Configurable span	Available range
Gauge pressure	0.5 to 32 MPa	-0.1 to 32 MPa
Absolute pressure	0.5 to 32 MPa	0 to 32 MPa abs

- For Capsule range code 1, 2, 3 and Bolts and nuts material K, H

	Configurable span	Available range
Gauge pressure	0.5 to 42 MPa	-0.1 to 42 MPa
Absolute pressure	0.5 to 42 MPa	0 to 42 MPa abs

- Capsule range code F

	Configurable span	Available range
Gauge pressure	0.5 to 16 MPa	-0.1 to 16 MPa
Absolute pressure	0.5 to 16 MPa	0 to 16 MPa abs

Accuracy:

1 MPa or higher: $\pm 0.2\%$ of span

Less than 1 MPa: $\pm 0.2\% \times (1 \text{ MPa} / \text{span})$ of span

Gauge pressure reference is 1013 hPa (1 atm)

Note: Gauge pressure variable is based on the above fixed reference and thus subject to be affected by the change of atmospheric pressure.

Working Pressure Limits (Silicone oil):

- Maximum Pressure Limits: Refer to "Pressure Limits".
- Minimum Pressure Limit: See graph below Figure 1-1

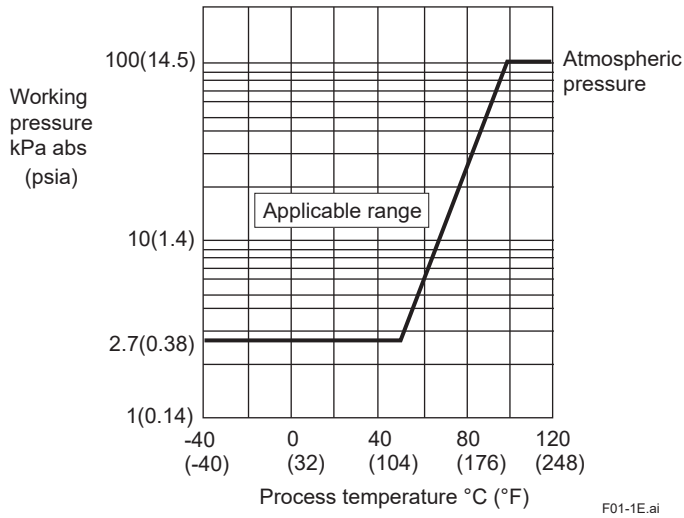

Figure 1-1. Working Pressure and Process Temperature

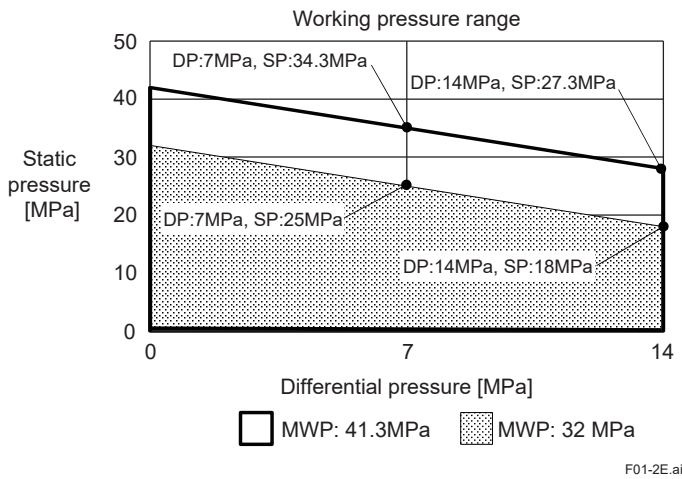

Figure 1-2. At MWP: 32/41.3 MPa: Operating pressure range

- MWP: 32 MPa (Bolts and Nuts material code: D, F, L)
- MWP: 41.3 MPa (Bolts and Nuts material code: K, H)

□ **Communication Specifications**

HART Communication:

Item		Description
Communication protocol		Two wire 4 to 20 mA DC output with digital communications HART
Output signal		Digital communication signal based on HART. 3.6 to 21.6 mA (-2.5 to 110%) Normal output range (default setting): 3.6 to 21.6 mA Burnout High side (default setting): 115% (22.4 mA DC) Burnout Low side (default setting): -5% (3.2 mA DC) For optional code /C2 Normal output range (default setting): 3.8 to 20.5 mA Burnout High side (default setting): 115% (22.4 mA DC) Burnout Low side (default setting): -5% (3.2 mA DC)
Output mode		Linear/Signal Characterizer (Max 30-segment)
Communication Requirements	Supply Voltage	For LCD Display and without display (Display and interface code: E, N) 10.5 to 42 V DC for general use and flameproof type. 10.5 to 30 V DC for intrinsically safe type. Minimum voltage limited at 16.4 V DC for digital communications For Graphic display (Display and interface code: F) 12 to 42 V DC for general use and flameproof type. Minimum voltage limited at 17.75 V DC for digital communications.
	Load	250 to 600Ω (including cable resistor) Working Pressure and Process Temperature for Figure 2
Response time (Typical)		Capsule Range code: M, H, V Wetted Parts material Code: S and L
		Capsule Range code: E, F, L, 1, 2, 3
Measurement period	Differential Pressure	35 ms
	Static pressure	35 ms
	Capsule Temperature	2 s
	Main module Temperature	1 s
Output signal at Failure Alarm		Output current value (Burnout), Communication, Indicator (Support for NAMUR NE107)
External Zero Adjustment		External zero is continuously adjustable with 0.01% incremental resolution of span.
Zero Adjustment Limits		Zero can be fully elevated or suppressed, within the lower and upper range limits of the capsule.
Display	LCD Display	Process value (5-digit, up to 4 different process values) Unit display (6-digit), Bar graph, Alarm message, NE107 status is displayed
	Graphic Display	Graphical LCD display (128×80 pixels display) with a color backlight, Process value (5-digit, up to 4 different process values), Unit display (6-digit), Bar graph, Alarm message, NE107 status is displayed, Display rotation selection Display language: English, French, German, Italian, Spanish, Portuguese, Russian, Chinese, Japanese
Local Parameter Setting	LCD Display	Loop test (test output), Tag number setting, Measurement range unit setting, Lower limit (LRV) and Upper limit (URV) of measurement range, Damping time constant setting, Output mode (proportional/square root) setting, Display content selection, Range resetting using actual pressure (LRV/URV), Burnout direction setting, setting of write-protect, Display of device information.
	Graphic Display	Loop test (test output), Tag number setting, Measurement range unit setting, Lower limit (LRV) and Upper limit (URV) of measurement range, Damping time constant setting, Output mode (proportional/square root) setting, Display content selection, Range resetting using actual pressure (LRV/URV), Burnout direction setting, setting of write-protect, Display of device information, Multiple display selection, Backlight color selection, Display rotation selection, language selection, LCD contrast selection
Diagnostics function		The following items are detected and output current value, communication, and indicator. Sensor error, Module error, Process error (out of equipment specification range, out of measurement range), Parameter setting value error, High/Low alarm for measured pressure.
Advanced functions		Heat trace monitoring: The change of the process connection temperature calculated by using the two temperature sensors built enables to detect the heat trace breakage or the abnormal temperature due to the failure.
		Impulse line blockage detection: The impulse line condition can be calculated and detected by extracting the fluctuation component from the differential pressure and static pressure signals. The EJX S detects the impulse line abnormality particularly which side of impulse line is plugged.

• Display and interface code: E or N

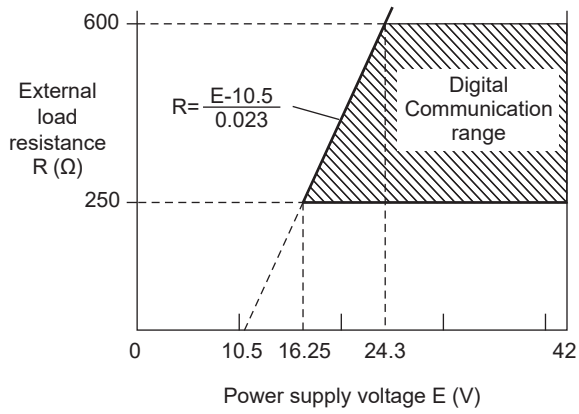

• Display and interface code: F

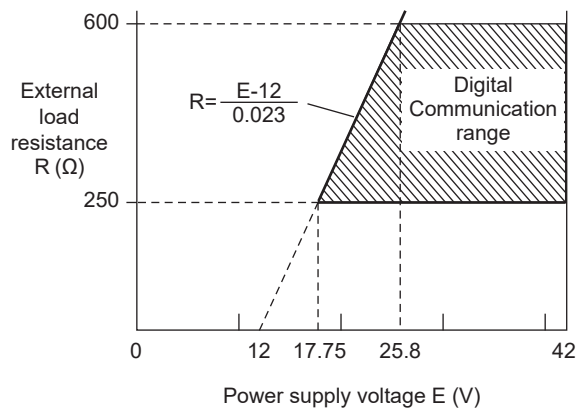

F02E.ai

Figure 2. Relationship Between Power Supply Voltage and External Load Resistance

PROFINET Communication:

Item		Description	
Communication protocol		Ethernet-APL Port Profile Specification Ver 1.1 (IEEE 802.3cg-2019) PROFINET Ver 2.45 (IEC 61158 Type 10, IEC 61784-2 CPF3) PA Profile 4.0	
Output signal		Digital communication signal based on PROFINET	
Output mode		Linear/Signal Characterizer (Max 30-segment)	
Communication Requirements	Supply Voltage	9 to 15 V DC for intrinsically safe type.	
	Load	N/A	
Response time (Typical)		Capsule Range code: M, H, V Wetted Parts material Code: S and L	150 ms
		Capsule Range code: E, F, L, 1, 2, 3	210 ms
Measurement period	Differential Pressure	35 ms	
	Static Pressure	35 ms	
	Capsule Temperature	2 s	
	Main module Temperature	1 s	
Function Block		AI × 3, Totalizer × 1	
Output signal at Failure Alarm		Communication, Indicator (Support for NAMUR NE107)	
External Zero Adjustment		External zero is continuously adjustable with 0.01% incremental resolution of span.	
Zero Adjustment Limits		Zero can be fully elevated or suppressed, within the lower and upper range limits of the capsule.	
Display	LCD Display	Process value (5-digit, up to 4 different process values) Unit display (6-digit), Bar graph, Alarm message, NE107 status is displayed	
	Graphic Display	Graphical LCD display (128×80 pixels display) with a color backlight, Process value (5-digit, up to 4 different process values), Unit display (6-digit), Bar graph, Alarm message, NE107 status is displayed, Display rotation selection Display language: English, French, German, Italian, Spanish, Portuguese, Russian, Chinese, Japanese	
Local Parameter Setting	LCD Display	Display of device information (VendorID, DeviceID, Station name, IP address)	
	Graphic Display	Display of device information (VendorID, DeviceID, Station name, IP address) Setting can be changed. Multiple display selection, Backlight color selection, Display rotation selection, language selection, LCD contrast selection	
Diagnostics function		The following items are detected and communication, and indicator. Sensor error, Module error, Process error (out of equipment specification range, out of measurement range), Parameter setting value error.	
Advanced functions		Heat trace monitoring: The change of the process connection temperature calculated by using the two temperature sensors built enables to detect the heat trace breakage or the abnormal temperature due to the failure.	
		Impulse line blockage detection: The impulse line condition can be calculated and detected by extracting the fluctuation component from the differential pressure and static pressure signals. The EJX S detects the impulse line abnormality particularly which side of impulse line is plugged.	

□ **Conformity Standards**

Degrees of protection:

IP66/IP67/IP68 (maximum depth of 20 meters up to 168 hours),
Type 4X

Explosion Protected type:

Canada, US, ATEX, IECEx
Refer to “EXPLOSION PROTECTED TYPE” for details.

EMC Conformity Standards:

EN 61326-1: Class A, Table 2(*1)
EN 61326-2-3
*1: Tested in accordance with IEC 61000-4 series, as specified in EN 61326-1

European Pressure Equipment Directive 2014/68/EU:

With option code /PE3 (for M, H and V capsules and wetted parts material code S.)
Category III, Module H, Type of Equipment: Pressure Accessory-Vessel, Type of Fluid: Liquid and Gas, Group of Fluid: 1 and 2
Sound Engineering Practice (for all capsules)

Environmental regulations:

- EU RoHS Directive: EN IEC 63000
- REACH Statement: Regulation EC 1907/2006
- China RoHS: GB 26572
- Toxic Substances Control Act: TSCA: US Toxic Substances Control Act (TSCA) Section 6(h)

Safety Requirement Standards:

- EN61010-1
- Installation category: (Anticipated transient overvoltage 330 V)
 - Pollution degree: 2
 - Indoor/Outdoor use

SIL Certification:

Compliant with conformity standard IEC 61508 (Functional Safety of Electrical/Electronic/Programmable Electronic Safety-related Systems).
Compliant with SIL 2. Compliant with SIL 3 if two instruments are used in a redundant configuration.
The safety data varies depending on the hardware/software revision.
Read the Safety Manual for details. (Document No.: T1 01C33A01-01ZN)
The Functional Safety Manual can be downloaded from our website.
URL: <https://www.yokogawa.com/solutions/products-platforms/field-instruments/>

Marking:

- CE marking
- RCM marking
- Morocco conformity marking
- cFMUS marking

Approval code	CE	RCM	Morocco conformity	cFMUS
-C□□, -F□□		✓	✓	✓
-KF1, -KS1, -KU1, -KNN	✓	✓	✓	
-SF1, -SS1, -SU1		✓	✓	
-VU1	✓	✓	✓	✓
-NNN		✓	✓	

□ **Normal Operating Condition**

Supply Voltage:

Refer to “Communication Specifications.”

Ambient Temperature Limits:

- 40 to 85°C (-40 to 185°F) Except for Capsule range code E
- 25 to 80°C (-13 to 176°F) For Capsule range code E
- 30 to 80°C (-22 to 176°F) with Display

In case of explosion protected types, refer to “EXPLOSION PROTECTED TYPE.”

Process Temperature Limits:

- 40 to 120°C (-40 to 248°F) Except for Capsule range code E
- 25 to 80°C (-13 to 176°F) For Capsule range code E

In case of explosion protected types, refer to “EXPLOSION PROTECTED TYPE.”

Ambient Humidity Limits:

0 to 100% RH

Vibration Resistance:

0.21 mm (10-60 Hz), 3 G (60-2000 Hz)

Shock Resistance:

50 G 11 ms (de-energized, with half-sine wave pulse in three directions)

Noise Resistance:

EN61326, NAMUR NE21

Grounding:

Class-C grounding (Ground resistance 10Ω or less)

□ **Physical Specifications**

Electrical connection:

Refer to “MODEL AND SUFFIX CODES.”

Process connections:

Refer to “MODEL AND SUFFIX CODES.”

Material:

- Wetted Parts Materials: Refer to “MODEL AND SUFFIX CODES.”
- Bolting: B7 carbon steel, 316L SST or 660 SST
- Housing: Low copper cast aluminum alloy
- Name plate and tag: 316 SST
- Cover O-rings: Buna-N,
- Fill fluid: Silicone, Fluorinated oil
- Process connector gasket/O-ring

Code	Material/Form
Capsule range: E, F, L, M, H, V	PTFE Teflon Gasket
Capsule range: 1, 2, 3 or Optional codes /N2, /N3	Fluorinated rubber O-ring

Coating of housing:

[for aluminum housing]

Polyester resin powder coating Mint-green paint (RAL190 30 15)

[for option code /P□ or /X2]

Epoxy and polyurethane resin solvent coating

Mounting:

2 inch pipe mounting

Weight:

3.0 kg (6.6 lb)* for Wetted parts material code S and L, Capsule range code M, H and V

3.9 kg (8.6 lb)* for Capsule range code E and F

7.0 kg (15.4 lb)* for Capsule range code 1, 2, and 3

* Without Display, mounting bracket, and process connector.

■ MODEL AND SUFFIX CODES

● EJX110S Low working and Standard working pressure type

Model	SuffixCode	Description
EJX110S		Differential Pressure Transmitter
Approval	-CF1	Canada explosion-proof(*1)(*2)
	-CS1	Canada intrinsically safe(*1)(*2)
	-CU1	Canada explosion-proof and intrinsically safe(*1)(*2)
	-CNN	Canada safety requirement(*1)(*2)
	-FF1	USA explosion-proof(*1)(*2)
	-FS1	USA intrinsically safe(*2)
	-FU1	USA explosion-proof and intrinsically safe(*1)(*2)
	-FNN	USA safety requirement(*1)(*2)
	-KF1	ATEX flameproof(*1)(*2)
	-KS1	ATEX intrinsically safe(*2)
	-KU1	ATEX flameproof and intrinsically safe(*1)(*2)
	-KNN	CE marking(*1)
	-SF1	IECEX flameproof approval(*1)(*2)
	-SS1	IECEX intrinsically safe(*2)
	-SU1	IECEX flameproof and intrinsically safe(*1)(*2)
	-VU1	IECEX, ATEX, USA and Canada explosion-proof, intrinsically safe combination(*1)(*2)
	-NNN	None(*1)
Output signal	-J	4 to 20 mA DC with digital communication (HART protocol)
	-T	PROFINET over Ethernet-APL(*3)
Housing	1	Material: Cast-aluminum alloy
Electrical Connection	0	G1/2 female, one electrical connection without blind plugs
	2	1/2NPT female, two electrical connections without blind plugs
	4	M20 female, two electrical connections without blind plugs
	5	G1/2 female, two electrical connections with a blind plug
	7	1/2NPT female, two electrical connections with a blind plug
	9	M20 female, two electrical connections with a blind plug
	A	G1/2 female, two electrical connections with a 316 SST blind plug
	C	1/2NPT female, two electrical connections with a 316 SST blind plug
	D	M20 female, two electrical connections with a 316 SST blind plug
	F	G1/2 female, two electrical connections without blind plugs
P	M20 female and 1/2NPT female dual connection without blind plugs	
Display and interface	E	LCD display
	F	Graphic display(*11)
	N	Without display
Capsule range	-E	1 kPa / 100 mmH ₂ O / 4 inH ₂ O / 10 mbar (Only in combination with wetted parts material code: S and fill fluid code: H)(*12)
	-F	5 kPa / 20 inH ₂ O / 50 mbar / 500 mmH ₂ O (Wetted parts material code: S, F, G) (Fill fluid code S, D)
	-L	10 kPa / 40 inH ₂ O / 100 mbar / 1000 mmH ₂ O (Wetted parts material code: H, M, T, A, D, B, W) (Fill fluid code S, D)
	-M	100 kPa / 400 inH ₂ O / 1000 mbar / 10000 mmH ₂ O (Compatible with all wetted parts material codes) (Fill fluid code S, D)
	-J	100 kPa / 400 inH ₂ O / 1000 mbar / 10000 mmH ₂ O, Medium damping (Wetted parts material code: S, F, G) (Fill fluid code S only)
	-P	100 kPa / 400 inH ₂ O / 1000 mbar / 10000 mmH ₂ O, High damping (Wetted parts material code: S, F, G) (Fill fluid code H only)
	-H	500 kPa / 2000 inH ₂ O / 5000 mbar/ 5 kgf/cm ² (Fill fluid code S, D)
	-K	500 kPa / 2000 inH ₂ O / 5000 mbar/ 5 kgf/cm ² , Medium damping (Wetted parts material code: S, F, G) (Fill fluid code S only)
	-Q	500 kPa / 2000 inH ₂ O / 5000 mbar/ 5 kgf/cm ² , High damping (Wetted parts material code: S, F, G) (Fill fluid code H only)
-V	14 MPa / 2030 psi (Fill fluid code S, D)	

Model	SuffixCode	Description
Wetted Parts Material(*4)	<input type="checkbox"/>	Refer to "Wetted Parts Material" table below
Fill fluid	S	Silicone oil
	H	Silicone oil for low pressure or high damping
	D	Fluorinated oil(*5) Operating temperature -20 to 80°C (-4 to 176°F)
Process Connection	0	Without process connector (Rc1/4 female on cover flange)
	1	With Rc1/4 female process connector
	2	With Rc1/2 female process connector
	3	With 1/4NPT female process connector
	4	With 1/2NPT female process connector
	5	Without process connector (1/4NPT female on cover flange)
	W	Assembled with low volume cover flanges for diaphragm seal units with two M12 x 1.25 female threads, and shipped with two new capsule gaskets and O-rings.(*6)(*7)
Bolts and Nuts material	C	660 SST
	G	316L SST
	J	ASTM-B7 carbon steel
Installation	2	Vertical impulse piping type, right side high pressure, process connectors upside
	3	Vertical impulse piping type, right side high pressure, process connector downside
	6	Vertical impulse piping type, left side high pressure, process connectors upside
	7	Vertical impulse piping type, left side high pressure, process connectors downside
	8	Horizontal impulse piping type, right side high pressure
	9	Horizontal impulse piping type, left side high pressure(*7)(*8)
	B	Bottom process connection type, left side high pressure(*7)
	U	Universal flange
Mounting Bracket	-B	304 SST 2-inch pipe mounting (flat type)
	-D	304 SST 2-inch pipe mounting (L type)
	-J	316 SST 2-inch pipe mounting (flat type)
	-K	316 SST 2-inch pipe mounting (L type)
	-M	316 SST 2-inch pipe mounting (for bottom process connection)(*7)
	-P	316 SST 2-inch pipe mounting, position adjustable L type (for vertical piping)(*9)
	-N	None
Orifice for low flow measurement(*10)	N	None
Optional codes		<input type="checkbox"/> Optional specifications

- *1: Not applicable for output signal code T.
- *2: Not applicable for electrical connection code 0, 5, 9, A and F.
- *3: Not applicable for display and interface code F and N.
The approval code -FS1, -KS1 or -SS1 must be selected.
- *4:  Users must consider the characteristics of selected wetted parts material and the influence of process fluids. The use of inappropriate materials can result in the leakage of corrosive process fluids and cause injury to personnel and/or damage to plant facilities. It is also possible that the diaphragm itself can be damaged and that material from the broken diaphragm and the fill fluid can contaminate the user's process fluids.
Be very careful with highly corrosive process fluids such as hydrochloric acid, sulfuric acid, hydrogen sulfide, sodium hypochlorite, and high-temperature steam (150°C [302°F] or above). Contact Yokogawa for detailed information of the wetted parts material.
- *5: Oil-prohibited use (degreasing cleaning) or dehydrating treatment, select the additional specification code for oil-prohibited use (/K01, /K41) or oil-prohibited use with dehydrating treatment (/K05, /K45).
- *6: Applicable with capsule range code M, H, V and installation code 9.
- *7: Applicable with wetted parts material code S, F and G.
- *8: Not applicable for capsule range code E.
- *9: For position adjustable bracket, refer to SD 01C33B10-01EN.
- *10: For low flow measurement type refer to GS 01C33C10-02EN.
- *11: Not applicable for approval code -CS1, -CU1, -FS1, -FU1, -KS1, -KU1, -SS1, -SU1 and -VU1.
- *12: Not applicable for approval code -CF1, -CU1 and -VU1.

Table. Wetted Parts Materials

Wetted parts material code	Cover flange and process connector	Capsule	Capsule gasket	Vent/Drain plug
S #	ASTM CF-8M(*1)(*8)	Hastelloy C-276(*6) (Diaphragm) F316L SST, 316L SST (Others)	Teflon-coated 316L SST	316 SST
L #	ASTM CF-3M(*2)(*8)	Hastelloy C-276(*6) (Diaphragm) F316L SST, 316L SST (Others)	Teflon-coated 316L SST	316L SST
H #	ASTM CF-8M(*1)(*8)	Hastelloy C-276(*6)	PTFE Teflon	316 SST
M #	ASTM CF-8M(*1)(*8)	Monel	PTFE Teflon	316 SST
T	ASTM CF-8M(*1)(*8)	Tantalum	PTFE Teflon	316 SST
A #	Hastelloy C-276 equivalent(*3)	Hastelloy C-276(*6)	PTFE Teflon	Hastelloy C-276 (*6)
D	Hastelloy C-276 equivalent(*3)	Tantalum	PTFE Teflon	Hastelloy C-276 (*6)
B #	Monel equivalent(*4)	Monel	PTFE Teflon	Monel
W #	Super Duplex SST equivalent(*5)	Hastelloy C-276(*6)	PTFE Teflon	Super Duplex SST (*7)
F #	ASTM CF-8M(*1)(*8)	Hastelloy C-276(*6) / Gold-plated (3 μm) (Diaphragm), F316L SST, 316L SST (Others)	Teflon-coated 316L SST	316 SST
G #	ASTM CF-8M(*1)(*8)	Hastelloy C-276(*6) / Gold-plated (10 μm) (Diaphragm), F316L SST, 316L SST (Others)	Teflon-coated 316L SST	316 SST
J #	ASTM CF-3M(*2)(*8)	Hastelloy C-276(*6) / Gold-plated (3 μm) (Diaphragm), F316L SST, 316L SST (Others)	Teflon-coated 316L SST	316L SST
K #	ASTM CF-3M(*2)(*8)	Hastelloy C-276(*6) / Gold-plated (10 μm) (Diaphragm), F316L SST, 316L SST (Others)	Teflon-coated 316L SST	316L SST

*1: ASTM CF-8M or SCS14A. Cast version of 316 SST.
 *2: ASTM CF-3M or SCS16A. Cast version of 316L SST.
 *3: Hastelloy C-276 equivalent casting.
 *4: Indicated material is equivalent to ASTM M35-2.
 *5: Indicated material is equivalent to ASTM A995 Grade5A.
 *6: Hastelloy C-276 or Hastelloy C276 equivalent.
 *7: UNS S32750 or EN 1.4410.
 *8: Intergranular corrosion test passed according to ASTM A262 Practice E.
 The '# marks indicate the construction materials conform to NACE material recommendations per MR0175/ISO15156. Please refer to the latest standards for details. Selected materials also conform to NACE MR0103.

● EJX110S For High working pressure type

Model	SuffixCode	Description
EJX110S		Differential Pressure Transmitter
Approval	-CF1	Canada explosion-proof(*1)(*2)
	-CS1	Canada intrinsically safe(*1)(*2)
	-CU1	Canada explosion-proof and intrinsically safe(*1)(*2)
	-CNN	Canada safety requirement(*1)(*2)
	-FF1	USA explosion-proof(*1)(*2)
	-FS1	USA intrinsically safe(*2)
	-FU1	USA explosion-proof and intrinsically safe(*1)(*2)
	-FNN	USA safety requirement(*1)(*2)
	-KF1	ATEX flameproof(*1)(*2)
	-KS1	ATEX intrinsically safe(*2)
	-KU1	ATEX flameproof and intrinsically safe(*1)(*2)
	-KNN	CE marking(*1)
	-SF1	IECEX flameproof approval(*1)(*2)
	-SS1	IECEX intrinsically safe(*2)
	-SU1	IECEX flameproof and intrinsically safe(*1)(*2)
	-VU1	IECEX, ATEX, USA and Canada explosion-proof, intrinsically safe combination(*1)(*2)
-NNN	None(*1)	
Output signal	-J	4 to 20 mA DC with digital communication (HART protocol)
	-T	PROFINET over Ethernet-APL(*3)
Housing	1	Material: Cast-aluminum alloy
Electrical Connection	0	G1/2 female, one electrical connection without blind plugs
	2	1/2NPT female, two electrical connections without blind plugs
	4	M20 female, two electrical connections without blind plugs
	5	G1/2 female, two electrical connections with a blind plug
	7	1/2NPT female, two electrical connections with a blind plug
	9	M20 female, two electrical connections with a blind plug
	A	G1/2 female, two electrical connections with a 316 SST blind plug
	C	1/2NPT female, two electrical connections with a 316 SST blind plug
	D	M20 female, two electrical connections with a 316 SST blind plug
	P	G1/2 female, two electrical connections without blind plugs M20 female and 1/2NPT female dual connection without blind plugs
Display and interface	E	LCD display
	F	Graphic display(*7)
	N	Without display
Capsule range	-1	100 kPa / 400 inH ₂ O / 1000 mbar / 10000 mmH ₂ O, High Pressure (Fill fluid code S, D)
	-2	500 kPa / 2000 inH ₂ O / 5000 mbar / 5 kgf/cm ² , High pressure (Fill fluid code S, D)
	-3	14 MPa / 2000 psi, High Pressure (Fill fluid code S, D)
	-5	100 kPa / 400 inH ₂ O / 1000 mbar / 10000 mmH ₂ O, High Pressure and High damping (Fill fluid code H)
	-6	500 kPa / 2000 inH ₂ O / 5000 mbar / 5 kgf/cm ² , High pressure and High damping (Fill fluid code H)
Wetted Parts Material(*4)	<input type="checkbox"/>	Refer to "Wetted Parts Material" table below
Fill fluid	S	Silicone oil
	H	Silicone oil for high damping
	D	Fluorinated oil(*5) Operating temperature -20 to 80°C (-4 to 176°F)
Process Connections	0	Without process connector (Rc1/4 female on cover flange)
	1	With Rc1/4 female process connector
	2	With Rc1/2 female process connector
	3	With 1/4NPT female process connector
	4	With 1/2NPT female process connector
	5	Without process connector (1/4NPT female on cover flange)

Model	SuffixCode	Description
Bolts and Nuts material	D	660 SST [MWP] 32 MPa
	F	316L SST [MWP] 32 MPa
	H	316L SST [MWP] 41.3 MPa
	L	ASTM-B7 carbon steel [MWP] 32 MPa
	K	ASTM-B7 carbon steel [MWP] 41.3 MPa
Installation	2	Vertical impulse piping type, right side high pressure, process connectors upside
	3	Vertical impulse piping type, right side high pressure, process connectors downside
	6	Vertical impulse piping type, left side high pressure, process connectors upside
	7	Vertical impulse piping type, left side high pressure, process connectors downside
	8	Horizontal impulse piping type, right side high pressure
	9	Horizontal impulse piping type, left side high pressure
	U	Universal flange
Mounting Bracket	-B	304 SST 2-inch pipe mounting (flat type)
	-D	304 SST 2-inch pipe mounting (L type)
	-J	316 SST 2-inch pipe mounting (flat type)
	-K	316 SST 2-inch pipe mounting (L type)
	-M	316 SST 2-inch pipe mounting (for bottom process connection)
	-P	316 SST 2-inch pipe mounting, position adjustable L type (for vertical piping)(*6)
	-N	None
Orifice for low flow measurement	N	None
Optional codes		/□ Optional specifications

- *1: Not applicable for output signal code T.
- *2: Not applicable for electrical connection code 0, 5, 9, A and F.
- *3: Not applicable for display and interface code F and N.
The approval code -FS1, -KS1 or -SS1 must be selected.
- *4: ⚠ Users must consider the characteristics of selected wetted parts material and influence of process fluids. Specifying inappropriate materials has the potential to cause serious damage to human body and plant facilities resulted from an unexpected leak of the corrosive process fluids.
- *5: Oil-prohibited use (degreasing cleaning) or dehydrating treatment, select the additional specification code for oil-prohibited use (/K01, /K41) or oil-prohibited use with dehydrating treatment (/K05, /K45).
- *6: For position adjustable bracket, refer to SD 01C33B10-01EN.
- *7: Not applicable for approval code -CS1, -CU1, -FS1, -FU1, -KS1, -KU1, -SS1, -SU1 and -VU1.

Table. Wetted Parts Materials

Wetted parts material code	Cover flange	Process connector	Capsule	Capsule gasket	Vent/Drain plug
S #	F316 SST(*3)	ASTM CF-8M (*1)(*3)	Hastelloy C-276(*2) (Diaphragm) F316L SST, 316L SST (Others)	Teflon-coated 316L SST	316 SST
F #	F316 SST(*3)	ASTM CF-8M (*1)(*3)	Hastelloy C-276 / Gold-plated (3μ m) (Diaphragm), F316L SST, 316L SST (Others)	Teflon-coated 316L SST	316 SST
G #	F316 SST(*3)	ASTM CF-8M (*1)(*3)	Hastelloy C-276 / Gold-plated (10 μm) (Diaphragm), F316L SST, 316L SST (Others)	Teflon-coated 316L SST	316 SST

- *1: ASTM CF-8M or SCS14A. Cast version of 316 SST.
 - *2: Hastelloy C-276 or Hastelloy C276 equivalent.
 - *3: Intergranular corrosion test passed according to ASTM A262 Practice E.
- The # marks indicate the construction materials conform to NACE material recommendations per MR0175/ISO15156. Please refer to the latest standards for details. Selected materials also conform to NACE MR0103.

■ OPTIONAL SPECIFICATIONS / Approval for Explosion-proof

Item	Description	Code	
Flameproof packing adapter(*1)(*2)	Electrical connection: G1/2 female, Applicable cable outline: Ø8 to Ø12	1 pcs	/V11
		2 pcs	/V12

■ OPTIONAL SPECIFICATIONS / Hardware

Item	Description	Code	
High Accuracy type(*15)	Reference accuracy: ±0.025% of Span	/HAC	
High range ability	400:1 range ability for M capsule range	/CR1	
* For details, contact Yokogawa sales office	400:1 range ability for H capsule range	/CR2	
Plug option(*5)	Long vent(*3)(*4): Total length: 119 mm (standard: 34 mm); Total length when combining with option code K□□: 130 mm. Material: 316 SST	/U1	
	Without vent and drain plugs(*6)	/UN	
Additional blind plug(*5)(*7)	Additional blind plug is attached to the conduit connection on both sides for storing transmitter	/PP	
Painting	Color change	Color change, amplifier cover; Black	/P1
		Color change, amplifier cover; Jade green	/P2
		Color change, amplifier cover; Metallic silver	/P7
		Color change, amplifier and terminal covers Munsell code; 7.5 R4/14, Red	/PR
	Coating Change	High anti-corrosion coating: Housing, amplifier and terminal covers(*8)	/X2
Surge protective device	UL1449, UL497B compliant device (SPD). • 3 kA crest (8 x 20 microseconds) • 6 kV crest (1.2 x 50 microseconds) Exchangeable	/A	
Oil-prohibited use(*3)	Degrease cleansing treatment	/K01	
	Degrease cleansing treatment with certificates	/K41	
Oil-prohibited use with dehydrating treatment(*3)	Degrease cleansing and dehydrating treatment	/K05	
	Degrease cleansing and dehydrating treatment with certificates	/K45	
Wired tag plate	316 SST tag plate wired onto transmitter: up to 22 characters	/N4	
Nameplate Indication	Range field	Blank the calibration range on the nameplate	/N5
	Maximum Pressure Limits (MWP) unit(*36)	psi	/D1
		bar	/D3
		kgf/cm ²	/D4
High-humidity option(*9)	For high-humidity environments	/HE	
Bug screen(*5)(*33)	With bug screen to the process connection port of the low side cover flange	/BS	
Gold-plated capsule gasket(*10)	Gold-plated 316L SST capsule gasket. Without drain and vent plugs.	/GS	
Body option(*3)(*11)	Right side high pressure, without drain and vent plugs(*12)	/N1	
	N1 and Process connection, based on IEC61518 with female thread on both sides of cover flange, with blind kidney flanges on back(*13)(*14)	/N2	
	N2, and Material certificate for cover flange, diaphragm, capsule body, and blind kidney flange(*13)(*14)	/N3	
Functional safety(*35)	Without functional safety SIL 2	/SLN	

OPTIONAL SPECIFICATIONS / Software

Item		Description	Code	Output signal code	
				J	T
Failure operation		Analog output levels compliant with NAMUR NE43 (Output signal limits: 3.8 mA to 20.5 mA Output status)	/C2	○	
Date configuration at factory	Parameter Setting	For HART communication type: Software damping, Descriptor and Message	/CA	○	
		For HART communication type: Disabling external zero adjustment, Software damping, Descriptor and Message	/CJ	○	
		For PROFINET communication type: Software damping, Descriptor and Memo	/CB		○
	For PROFINET communication type: Disabling external zero adjustment, Software damping, Descriptor and Memo	/CK		○	
	Display Setting	Two engineering values are alternately displayed on the LCD.(*34)	/CF	○	○

OPTIONAL SPECIFICATIONS / Standards and Regulations

Item	Description	Code
European Pressure Equipment Directive(*16)	PED 2014/68/EU Category: III, Module: H, Type of Equipment: Pressure Accessory-Vessel, Type of Fluid: Liquid and Gas, Group of Fluid: 1 and 2	/PE3

OPTIONAL SPECIFICATIONS / Documents

Item	Description	Code	
Material certificate	Cover flange(*17)	/M01	
	Cover flange, Process connector(*18)	/M11	
	Cover flange, Bolt and nut for cover flange(*17)	/M61	
	Cover flange, Process connector, Bolt and nut for cover flange, Bolt for process connector(*18)	/M71	
	Cover flange, Diaphragm, Capsule body(*5)(*17)(*19)	/MA1	
	Cover flange, Process connector, Diaphragm, Capsule body(*18)(*20)	/MC1	
	Cover flange, Bolt and Nut for cover flange, Diaphragm, Capsule body, Vent and Drain plug, Vent screw, Capsule gasket(*5)(*17)(*21)	/MG1	
	Cover flange, Process connector Bolt and Nut for cover flange, Bolt for process connector Diaphragm, Capsule body, Vent and Drain plug, Vent screw, Capsule gasket(*18)(*21)	/MH1	
Material certificate list(*5)(*22)	Material certificate list	/YC	
Parameter list(*5)(*23)	List of setting and adjustment parameters	/YP	
Pressure test/Leak test certificate	Test Pressure: 50 kPa (7.25 psi)(*24)	Nitrogen Gas(*29) Retention time: one minute	/T04
	Test Pressure: 16 MPa (2300 psi)(*25)		/T12
	Test Pressure: 25 MPa (3600 psi)(*26)		/T13
	Test Pressure: 32 MPa (4500 psi)(*27)	Nitrogen Gas or Water(*30) Retention time: one minute	/T09
	Test Pressure: 41.3 MPa (6000 psi)(*28)		/T14
Pressure test/Leak test certificate	Submit pressure test certificate and leak test certificate separately. Test pressure: According to the test pressure on the Pressure and Leak Test certificate.	Pressure test: Test Fluid: Water(*30) Test time: ten minutes Leakage test: Test Fluid: Nitrogen Gas or Water(*30)(*29) Test time: ten minutes	/YT
Calibration certificate(*5)	Yokogawa measuring instruments control system	/L4	
	Yokogawa measuring instruments control system, and primary standards list	/L5	
	Yokogawa measuring instruments control system, primary standards list, and calibration equipments list	/L6	
	Yokogawa measuring instruments control system, primary standards list, calibration equipments list and their test cert	/L9	

OPTIONAL SPECIFICATIONS / Warranty

Item	Description	Code
Warranty	3-years warranty	/W3
	5-years warranty	/W5

- *1: Applicable for approval code -KNN and -NNN.
- *2: Applicable for electrical connection code 0, 5, A and F.
- *3: Applicable for wetted parts material code S, F, G, H, M and T.
- *4: Applicable for installation code 2, 3, 6 and 7.
- *5: Not applicable for process connection code W.
- *6: Not applicable for installation code U.
- *7: Applicable for electrical connection code 5, 7, 9, A, C and D. Not applicable for approval code -CF1, -CU1, -FF1, -FU1, -KF1, -KU1, -SF1, -SU1 and -VU1.
- *8: Not applicable with color change option.
- *9: Not applicable with flameproof packing adapter option code /V11 and /V12.
- *10: Applicable for wetted parts material code S, F and G; and process connection code 0 and 5; and installation code 8 and 9; and option code /M01, /M61, /M71, and /MA1. Not applicable for capsule range code E; and option code /U1, /UN, /N2 and /N3.
- *11: Applicable for installation code 9.
- *12: Applicable for mounting bracket code B, J and N.
- *13: Applicable for mounting bracket code N.
- *14: Not applicable with material certificate option /M□□.
- *15: Refer to "PERFORMANCE SPECIFICATIONS." Applicable for measurement span code M, H or V, and wetted parts material code S or L.
Not applicable for option code /A1, /A2, /K2, /K3, /K6, /K42 and /K46. When the specified range values for V capsule include negative value, the accuracy shall be the standard accuracy, even if /HAC is specified.
- *16: Applicable for approval code -KF1, -KS1, -KU1, -KNN, -SF1, -SS1, -SU1, -VU1 and capsule range code M, H, V, 1, 2, 3, 5 and 6; and wetted parts material code S, F and G.
- *17: Applicable for process connection code 0 and 5.
- *18: Applicable for process connection code 1, 2, 3 and 4.
- *19: Applicable for option code /UN, /N1, and /GS.
- *20: Applicable for option code /UN and /N1.
- *21: Not applicable for option code /UN, /N1, and /GS.
- *22: Applicable for material certificate option /M□□.
- *23: Applicable for output signal code J.
- *24: Applicable for capsule range code E; and bolts and nuts material code C, G and J.
- *25: Applicable for capsule range code F, L, J, K, P and Q or capsule range code M, H, V and wetted parts material code A, B, D, H, M, T and W.
- *26: Applicable for capsule range code M, H, V and wetted parts material code S, L, F, G, J and K.
- *27: Applicable for capsule range code 1, 2, 3, 5 and 6; and bolts and nuts material code D, F and L.
- *28: Applicable for capsule range code 1, 2, 3, 5 and 6; and bolts and nuts material code M, H, P and K.
- *29: Dry nitrogen gas is used for oil-prohibited use (option codes /K01, /K05, /K41 and /K45).
- *30: Pure water is used for oil-prohibited use (option codes /K01, /K05, /K41 and /K45).
- *31: Applicable for pressure test/leak test certificate code /T□□.
- *32: Applicable for electrical connection code 0, 2, 5, 7, A, C and F.
- *33: Not applicable for capsule range code 1, 2, 3, 5 and 6.
- *34: Not applicable for display and interface code N.
- *35: Required if output signal code T is selected.
- *36: The MWP (maximum working pressure) unit indicated on the housing nameplate is displayed in the unit specified by option codes /D1, /D3, and /D4.

DIMENSIONS

Unit: mm (approx.inch)

Wetted Parts Material Code: S, L, F, G, J, K and Capsule Range Code: M, H, V

• Vertical Impulse Piping Type

- Process connector upside (The drawing below is for Installation code 6.)

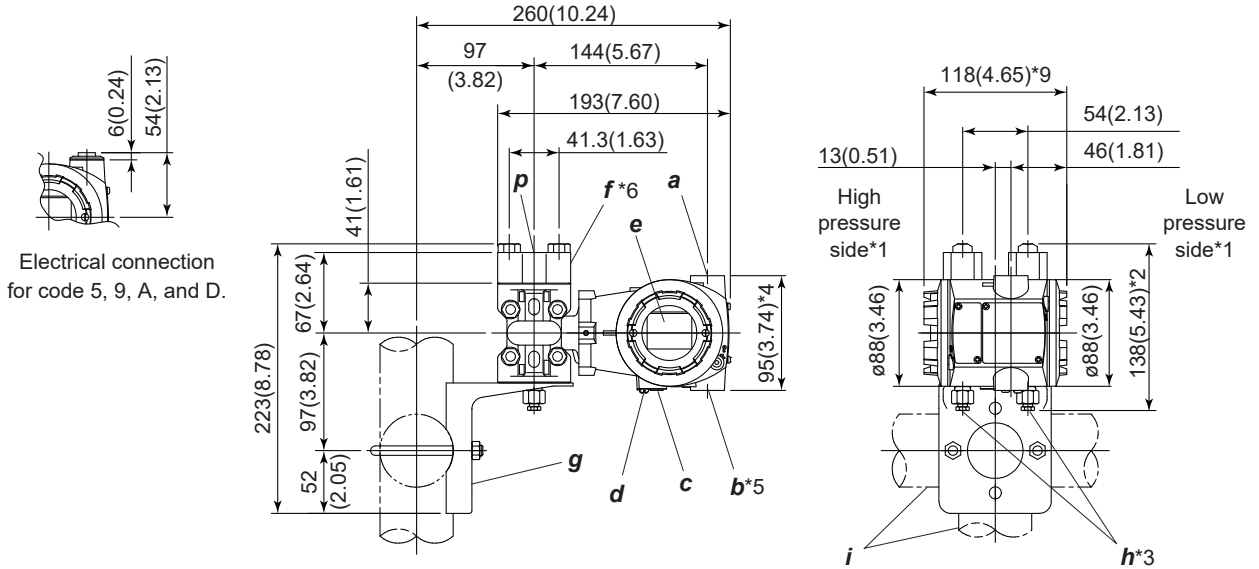

- Process connector downside (The drawing below is for Installation code 7.)

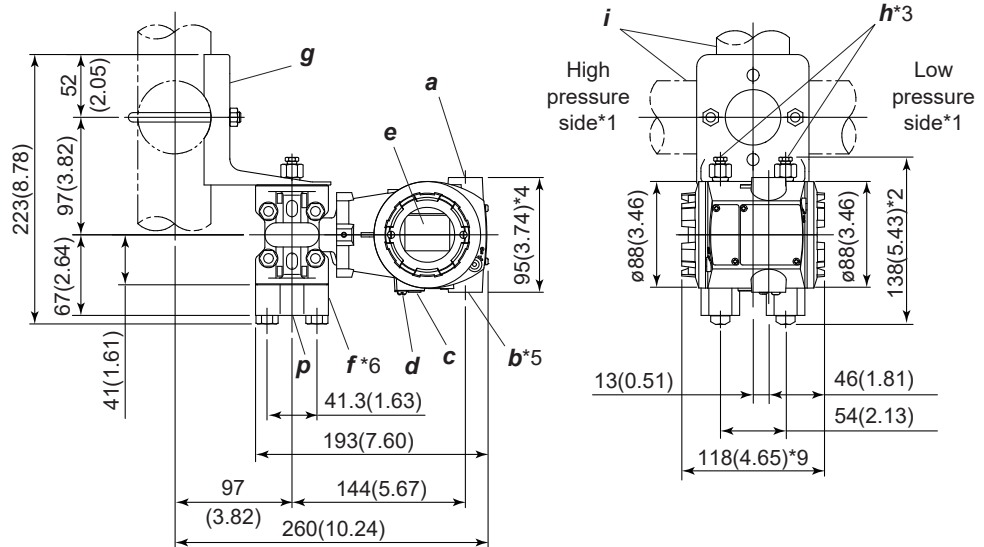

a	External indicator Conduit connection (optional)	e	Display (optional)	i	2-inch pipe (O.D. 60.5 mm)
b	Conduit connection	f	Process connector (optional)	p	Process connection
c	Zero adjustment	g	Mounting bracket (L-type, optional)		
d	Ground terminal	h	Vent/Drain plugs		

Unit: mm (approx.inch)

- Horizontal Impulse Piping Type (The drawing below is for Installation code 9.)

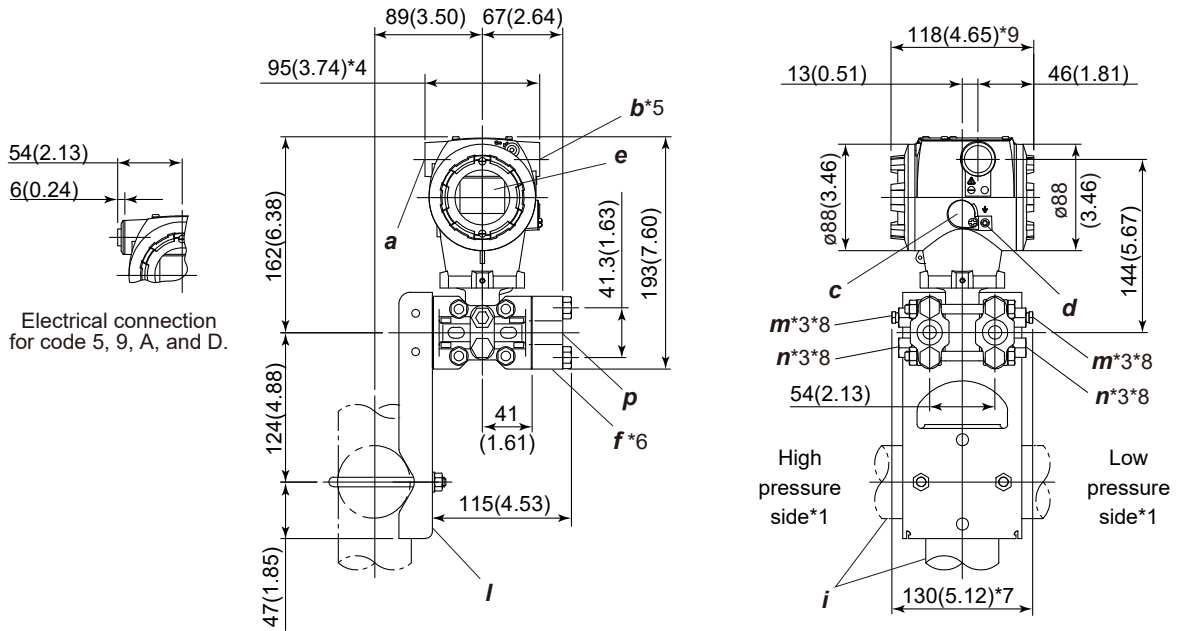

a External indicator Conduit connection (optional)	e Display (optional)	m Vent plug
b Conduit connection	f Process connector (optional)	n Drain plug
c Zero adjustment	i 2-inch pipe (O.D. 60.5 mm)	p Process connection
d Ground terminal	l Mounting bracket (Flat-type, optional)	

- *1: In case of Installation code 2, 3, or 8 is specified, high and low pressure side on the above figure are reversed. (i.e. High pressure side is on the right side)
- *2: In case of optional codes /K01, /K05, /K41 and /K45 specified, add 15 mm (0.59 inch).
- *3: In case of optional code /UN specified, plugs are not attached.
- *4: In case of electrical connection code 7 or C is specified, a blind plug is protruded by up to 8 mm (0.31 inch) from conduit connection.
- *5: In case of optional code /PP specified, a blind plug is attached to conduit connection on both sides.
- *6: In case of optional code /BS specified, a bug screen is installed to the process connection port of the low side cover flange, and no process connector is attached on the low pressure side.
- *7: In case of optional codes /K01, /K05, /K41 and /K45 specified, add 30 mm (1.18 inch).
- *8: In case of optional code /GS specified, plugs are not attached.
- *9: In case of Display and interface code N specified, it is 113 mm (4.45 inch).

Unit: mm (approx.inch)

Wetted Parts Material Code: A, B, D, H, M, T, W or Capsule Range Code: E, F, J, K, P, Q

• **Vertical Impulse Piping Type**

- Process connector upside (The drawing below is for Installation code 6.)

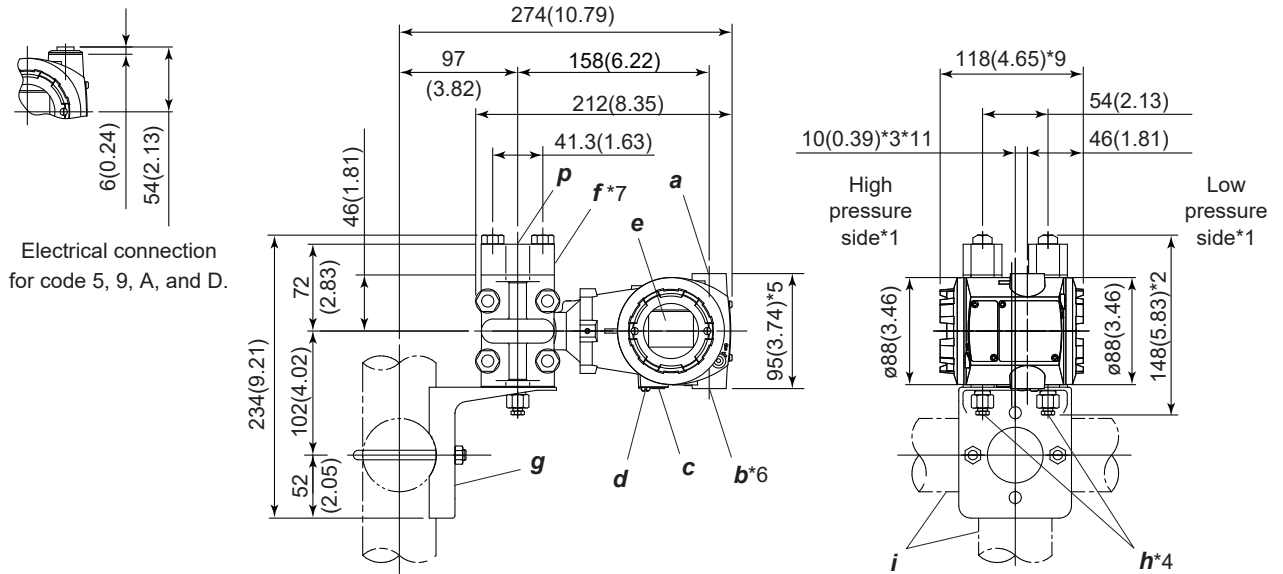

- Process connector downside (The drawing below is for Installation code 7.)

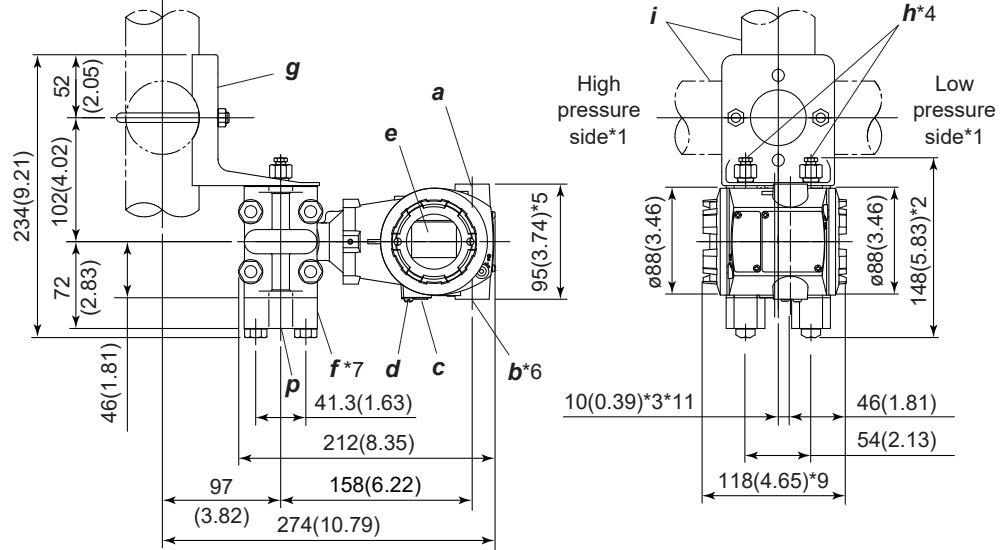

a External indicator Conduit connection (optional)	e Display (optional)	i 2-inch pipe (O.D. 60.5 mm)
b Conduit connection	f Process connector (optional)	p Process connection
c Zero adjustment	g Mounting bracket (L-type, optional)	
d Ground terminal	h Vent/Drain plugs	

Unit: mm (approx.inch)

- Horizontal Impulse Piping Type (The drawing below is for Installation code 9.)

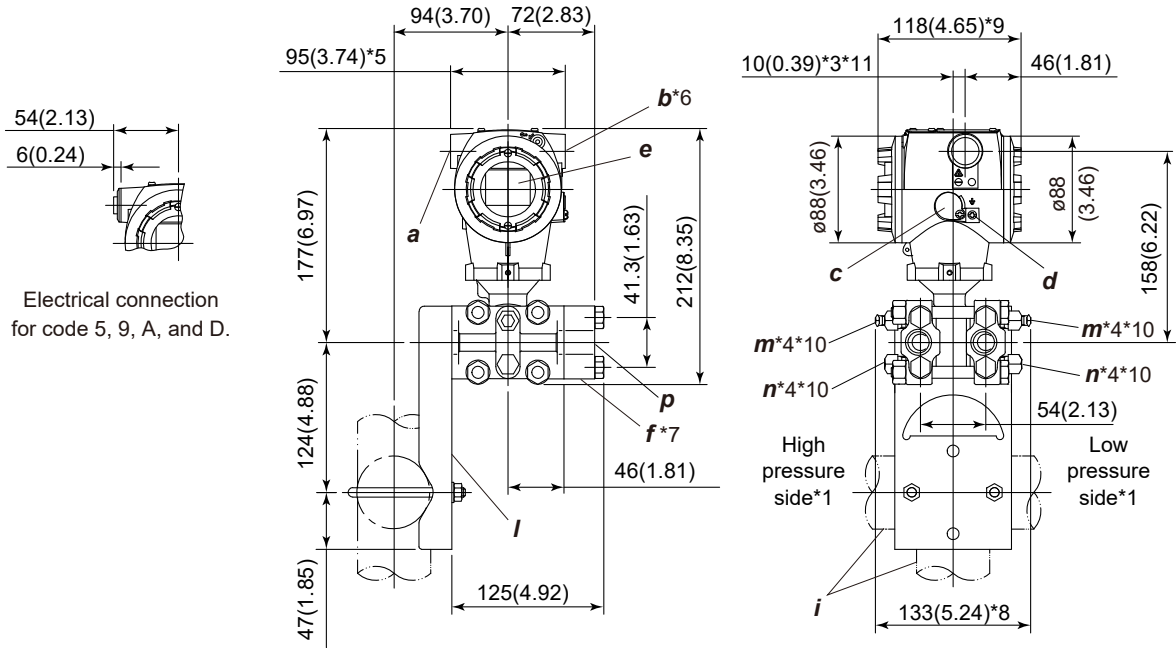

a	External indicator Conduit connection (optional)	e	Display (optional)	m	Vent plug
b	Conduit connection	f	Process connector (optional)	n	Drain plug
c	Zero adjustment	i	2-inch pipe (O.D. 60.5 mm)	p	Process connection
d	Ground terminal	I	Mounting bracket (Flat-type, optional)		

- *1: In case of Installation code 2, 3, or 8 is specified, high and low pressure side on the above figure are reversed. (i.e. High pressure side is on the right side)
- *2: In case of optional codes /K01, /K05, /K41 and /K45 specified, add 15 mm (0.59 inch).
- *3: In case of Installation code 2, 3, or 8 is specified, it is 16 mm (0.63 inch).
- *4: In case of optional code /UN specified, plugs are not attached.
- *5: In case of electrical connection code 7 or C is specified, a blind plug is protruded by up to 8 mm (0.31 inch) from conduit connection.
- *6: In case of optional code /PP specified, a blind plug is attached to conduit connection on both sides.
- *7: In case of optional code /BS specified, a bug screen is installed to the process connection port of the low side cover flange, and no process connector is attached on the low pressure side.
- *8: In case of optional codes /K01, /K05, /K41 and /K45 specified, add 30 mm (1.18 inch).
- *9: In case of Display and interface code N specified, it is 113 mm (4.45 inch).
- *10: In case of optional code /GS specified, plugs are not attached.
- *11: In case of Capsule range code E is specified, it is 13 mm (0.51 inch).

Unit: mm (approx.inch)

Capsule Range Code: 1, 2, 3, 5, 6 and Bolts and Nuts Material Code: D, F, L

• Vertical Impulse Piping Type

- Process connector upside (The drawing below is for Installation code 6.)

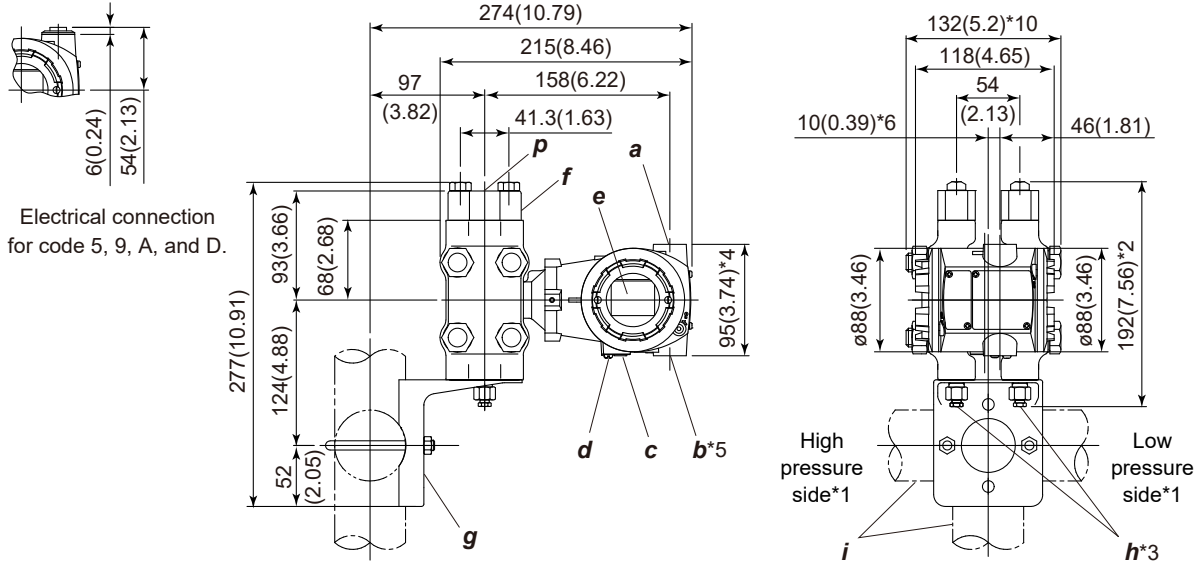

- Process connector downside (The drawing below is for Installation code 7.)

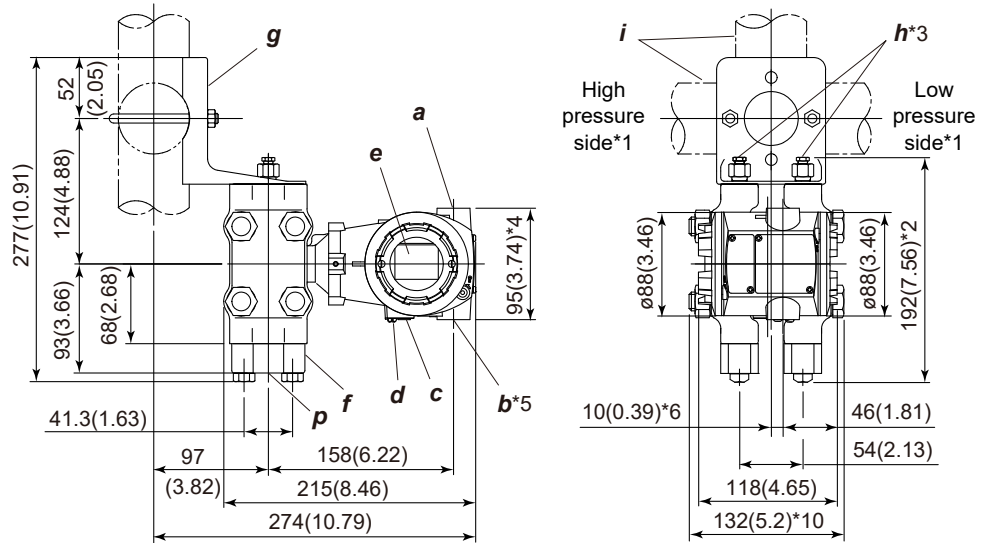

a External indicator Conduit connection (optional)	e Display (optional)	i 2-inch pipe (O.D. 60.5 mm)
b Conduit connection	f Process connector (optional)	p Process connection
c Zero adjustment	g Mounting bracket (L-type, optional)	
d Ground terminal	h Vent/Drain plugs	

Unit: mm (approx.inch)

● Horizontal Impulse Piping Type (The drawing below is for Installation code 9.)

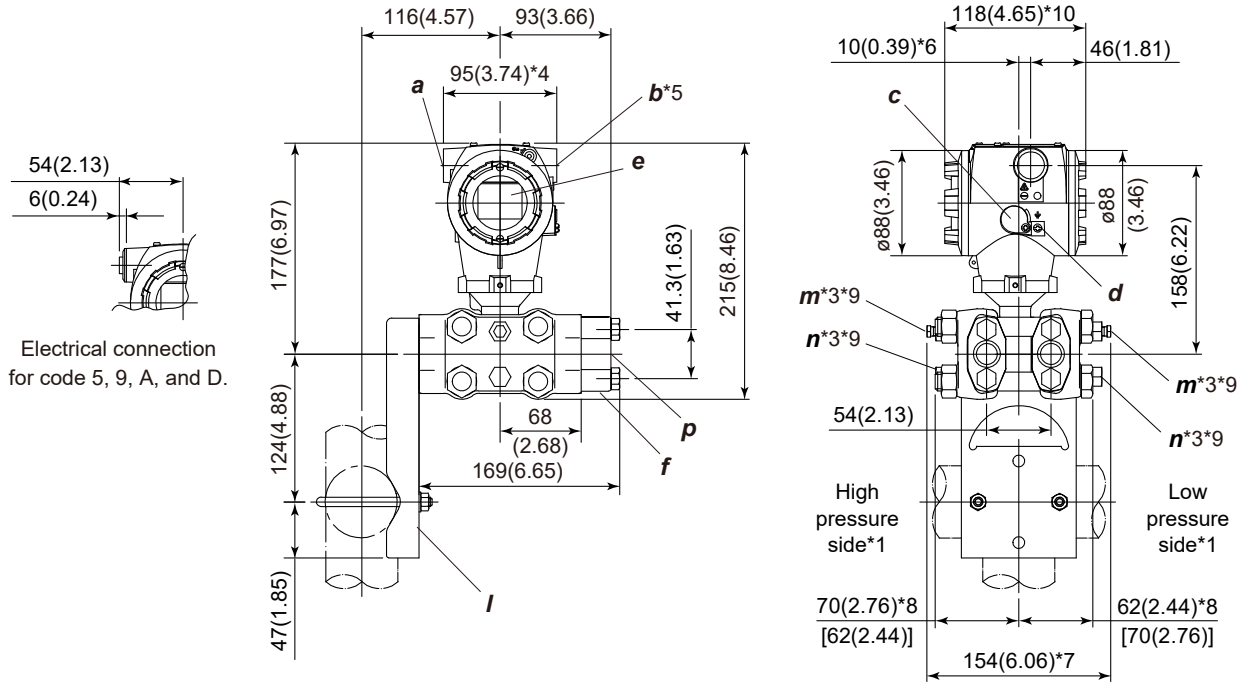

a	External indicator Conduit connection (optional)	e	Display (optional)	m	Vent plug
b	Conduit connection	f	Process connector (optional)	n	Drain plug
c	Zero adjustment	i	2-inch pipe (O.D. 60.5 mm)	p	Process connection
d	Ground terminal	l	Mounting bracket (Flat-type, optional)		

- *1: In case of Installation code 2, 3, or 8 is specified, high and low pressure side on the above figure are reversed. (i.e. High pressure side is on the right side.)
- *2: In case of optional codes /K01, /K05, /K41 and /K45 specified, add 15 mm (0.59 inch).
- *3: In case of optional code /UN specified, plugs are not attached.
- *4: In case of electrical connection code 7 or C is specified, a blind plug is protruded by up to 8 mm (0.31 inch) from conduit connection.
- *5: In case of optional code /PP specified, a blind plug is attached to conduit connection on both sides.
- *6: In case of Installation code 2, 3, or 8 is specified, it is 16 mm (0.63 inch).
- *7: In case of optional codes /K01, /K05, /K41 and /K45 specified, add 30 mm (1.18 inch).
- *8: Dimension value in case of optional code /UN. And in case of Installation code 8 is specified, dimension values are numbers enclosed in brackets "[]".
- *9: In case of optional code /GS specified, plugs are not attached.
- *10: In case of Display and interface code N specified, it is 113 mm (4.45 inch).

Unit: mm (approx.inch)

Capsule Range Code: 1, 2, 3, 5, 6 and Bolts and Nuts Material Code: K, H

• **Vertical Impulse Piping Type**

- Process connector upside (The drawing below is for Installation code 6.)

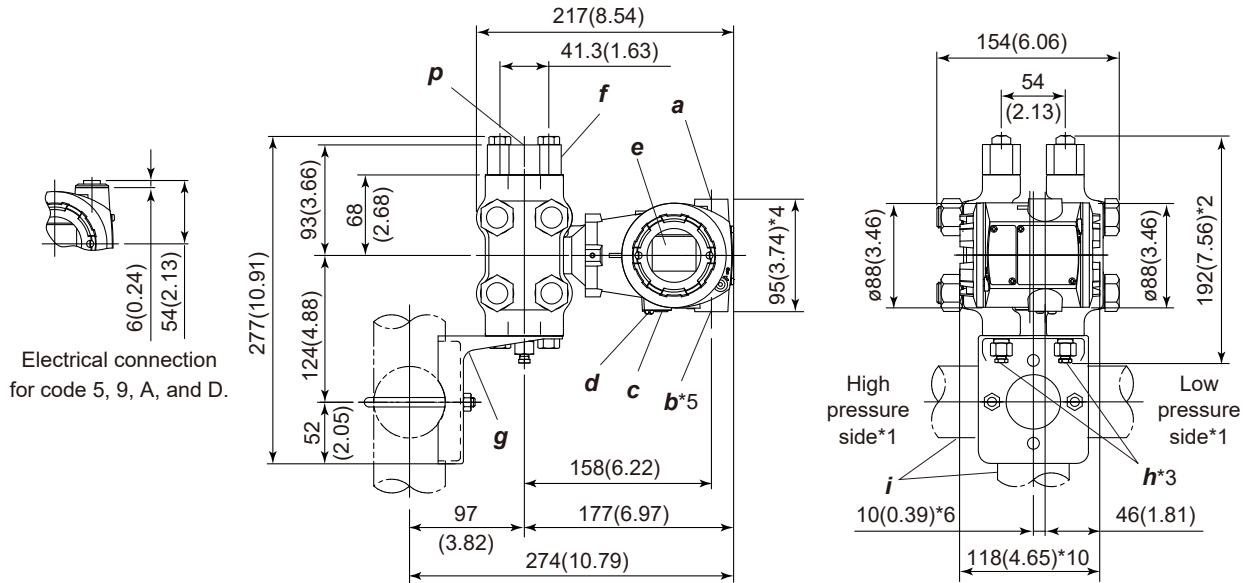

- Process connector downside (The drawing below is for Installation code 7.)

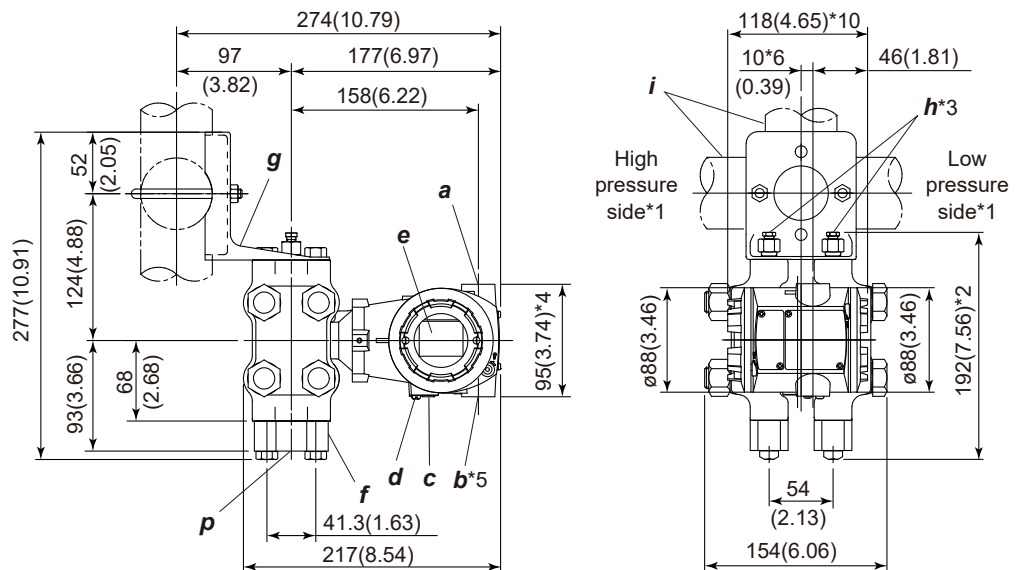

a External indicator Conduit connection (optional)	e Display (optional)	i 2-inch pipe (O.D. 60.5 mm)
b Conduit connection	f Process connector (optional)	p Process connection
c Zero adjustment	g Mounting bracket (L-type, optional)	
d Ground terminal	h Vent/Drain plugs	

Unit: mm (approx.inch)

● Horizontal Impulse Piping Type (The drawing below is for Installation code 9.)

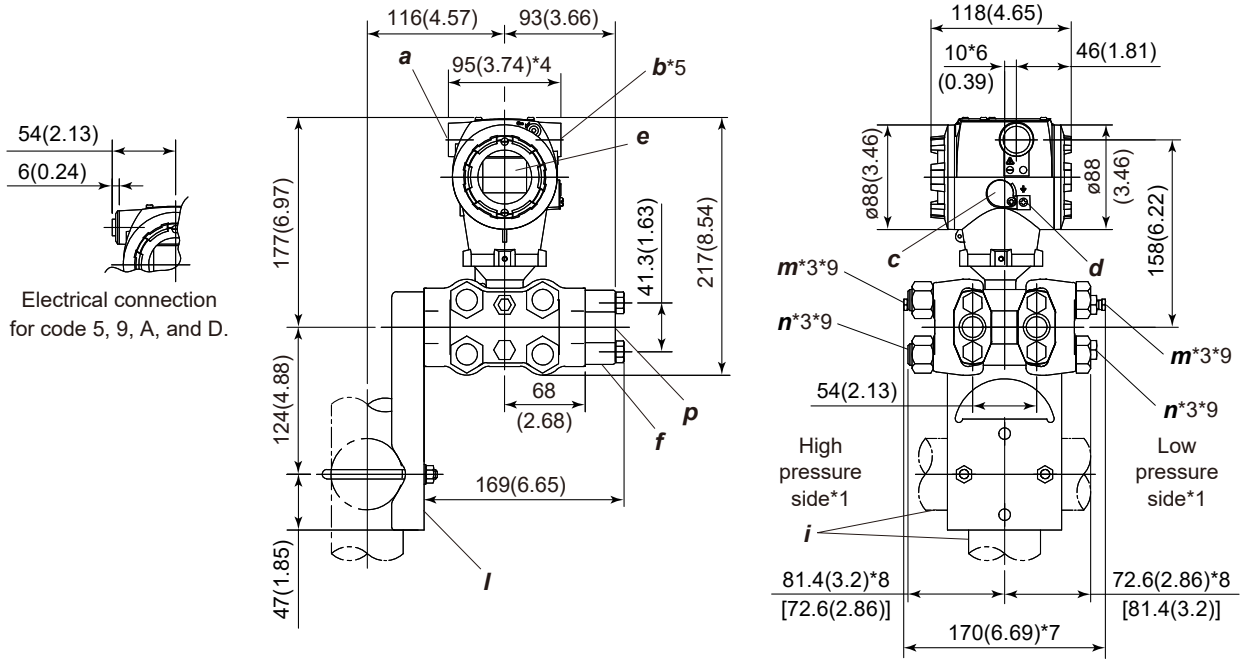

a	External indicator Conduit connection (optional)	e	Display (optional)	m	Vent plug
b	Conduit connection	f	Process connector (optional)	n	Drain plug
c	Zero adjustment	i	2-inch pipe (O.D. 60.5 mm)	p	Process connection
d	Ground terminal	l	Mounting bracket (Flat-type, optional)		

- *1: In case of Installation code 2, 3, or 8 is specified, high and low pressure side on the above figure are reversed. (i.e. High pressure side is on the right side.)
- *2: In case of optional codes /K01, /K05, /K41 and /K45 specified, add 15 mm (0.59 inch).
- *3: In case of optional code /UN specified, plugs are not attached.
- *4: In case of electrical connection code 7 or C is specified, a blind plug is protruded by up to 8 mm (0.31 inch) from conduit connection.
- *5: In case of optional code /PP specified, a blind plug is attached to conduit connection on both sides.
- *6: In case of Installation code 2, 3, or 8 is specified, it is 16 mm (0.63 inch).
- *7: In case of optional codes /K01, /K05, /K41 and /K45 specified, add 30 mm (1.18 inch).
- *8: Dimension value in case of optional code /UN. And in case of Installation code 8 is specified, dimension values are numbers enclosed in brackets "[]".
- *9: In case of optional code /GS specified, plugs are not attached.
- *10: In case of Display and interface code N specified, it is 113 mm (4.45 inch).

● Bottom Process Connection (The drawing below is for Installation code B.)

Unit: mm (approx.inch)

• Capsule Range Code: M, H, V

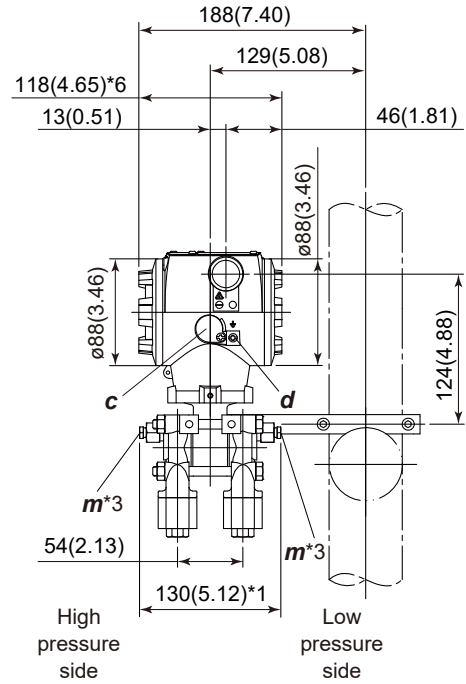
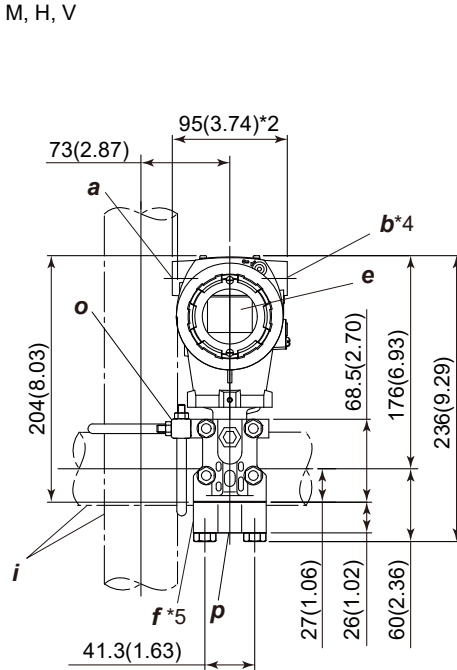
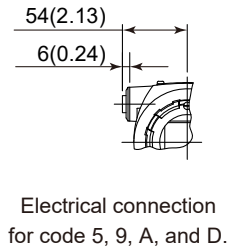

• Capsule Range Code: F, J, K, P, Q

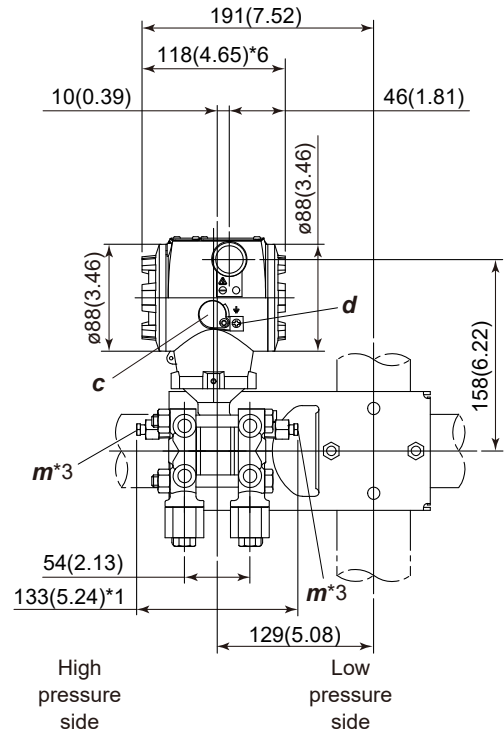
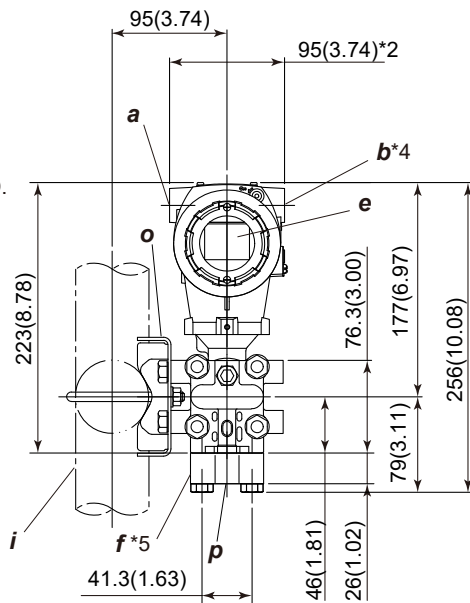
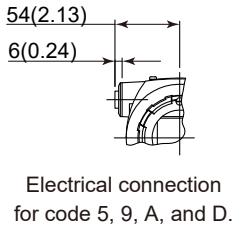

<i>a</i>	External indicator Conduit connection (optional)	<i>e</i>	Display (optional)	<i>o</i>	Mounting bracket (optional)
<i>b</i>	Conduit connection	<i>f</i>	Process connector (optional)	<i>p</i>	Process connection
<i>c</i>	Zero adjustment	<i>i</i>	2-inch pipe (O.D. 60.5 mm)		
<i>d</i>	Ground terminal	<i>m</i>	Vent plug		

*1: In case of optional codes /K01, /K05, /K41 and /K45 specified, add 30 mm (1.18 inch).

*2: In case of electrical connection code 7 or C is specified, a blind plug is protruded by up to 8 mm (0.31 inch) from conduit connection.

*3: In case of optional code /UN specified, plugs are not attached.

*4: In case of optional code /PP specified, a blind plug is attached to conduit connection on both sides.

*5: In case of optional code /BS specified, a bug screen is installed to the process connection port of the low side cover flange, and no process connector is attached on the low pressure side.

*6: In case of Display and interface code N specified, it is 113 mm (4.45 inch).

Unit: mm (approx.inch)

● Universal Flange (The drawing below is for Installation code U.)

- Capsule Range Code: M, H, V

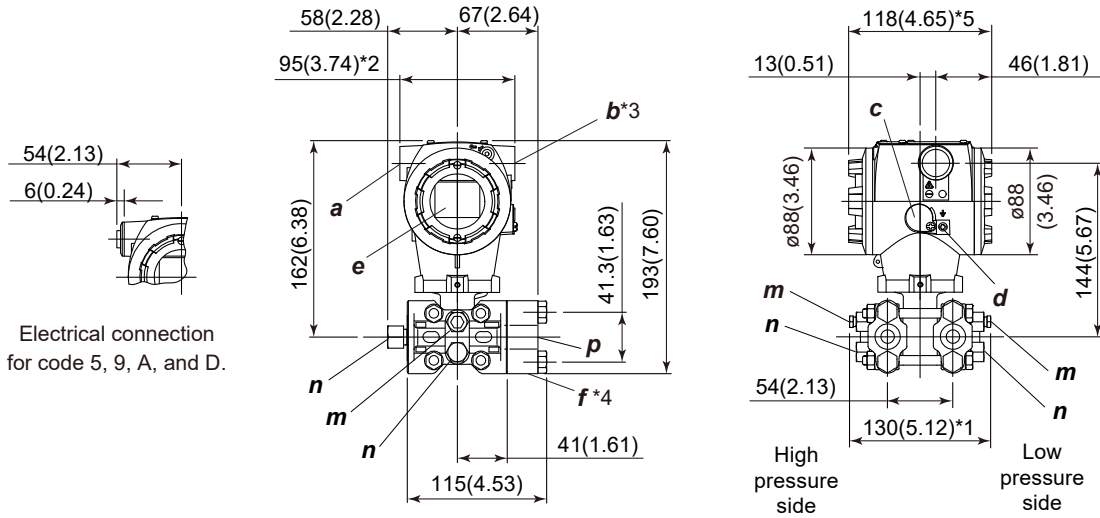

a	External indicator Conduit connection (optional)	d	Ground terminal	m	Vent plug
b	Conduit connection	e	Display (optional)	n	Drain plug
c	Zero adjustment	f	Process connector (optional)	p	Process connection

● Universal Flange (The drawing below is for Installation code U.)

- Capsule Range Code: E, F, J, K, P, Q

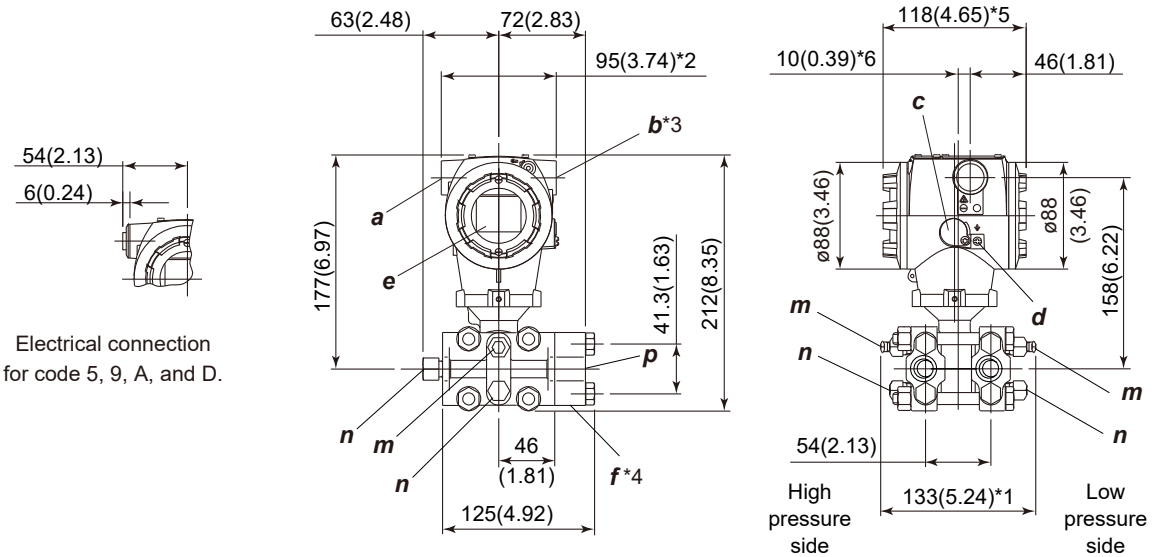

a	External indicator Conduit connection (optional)	d	Ground terminal	m	Vent plug
b	Conduit connection	e	Display (optional)	n	Drain plug
c	Zero adjustment	f	Process connector (optional)	p	Process connection

*1: In case of optional codes /K01, /K05, /K41 and /K45 specified, add 30 mm (1.18 inch).
 *2: In case of electrical connection code 7 or C is specified, a blind plug is protruded by up to 8 mm (0.31 inch) from conduit connection.
 *3: In case of optional code /PP specified, a blind plug is attached to conduit connection on both sides.
 *4: In case of optional code /BS specified, a bug screen is installed to the process connection port of the low side cover flange, and no process connector is attached on the low pressure side.
 *5: In case of Display and interface code N specified, it is 113 mm (4.45 inch).
 *6: In case of Capsule range code E is specified, it is 13 mm (0.51 inch).

Unit: mm (approx.inch)

• **Universal Flange (The drawing below is for Installation code U.)**

- Bolts and Nuts Material Code: D, F, L

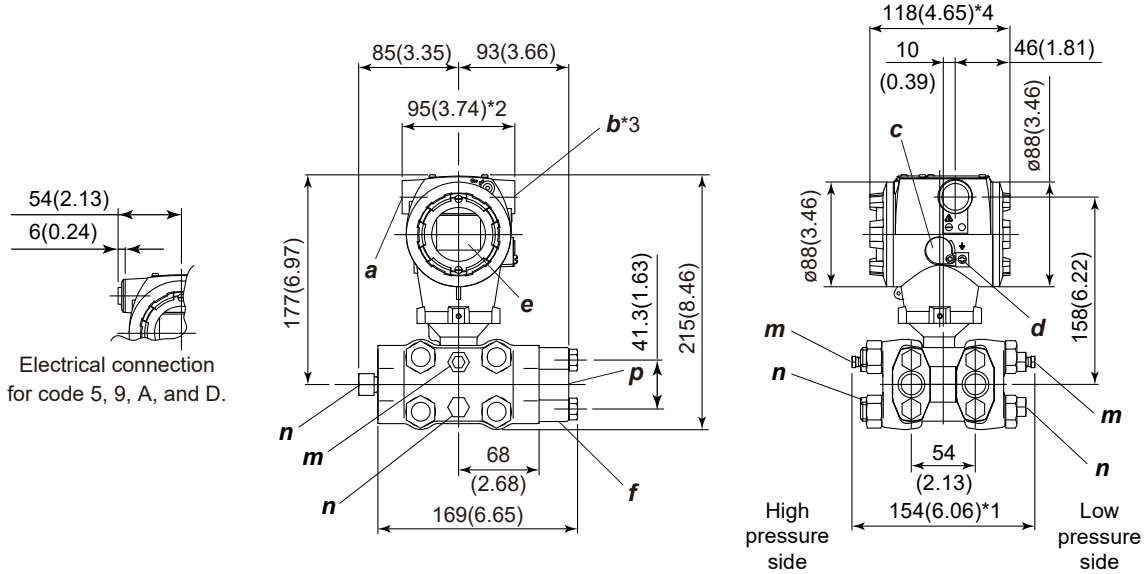

a	External indicator Conduit connection (optional)	d	Ground terminal	m	Vent plug
b	Conduit connection	e	Display (optional)	n	Drain plug
c	Zero adjustment	f	Process connector (optional)	p	Process connection

- Bolts and Nuts Material Code: K, H

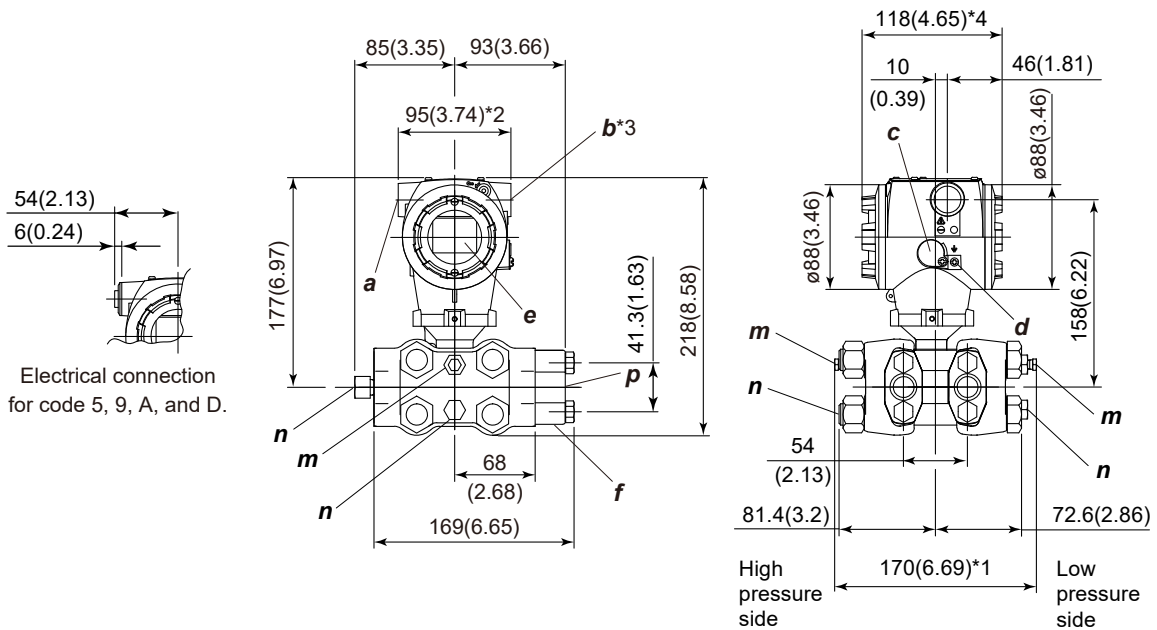

a	External indicator Conduit connection (optional)	d	Ground terminal	m	Vent plug
b	Conduit connection	e	Display (optional)	n	Drain plug
c	Zero adjustment	f	Process connector (optional)	p	Process connection

- *1: In case of optional codes /K01, /K05, /K41 and /K45 specified, add 30 mm (1.18 inch).
- *2: In case of electrical connection code 7 or C is specified, a blind plug is protruded by up to 8 mm (0.31 inch) from conduit connection.
- *3: In case of optional code /PP specified, a blind plug is attached to conduit connection on both sides.
- *4: In case of Display and interface code N specified, it is 113 mm (4.45 inch).

Unit: mm (approx.inch)

- With Process connection code W*1

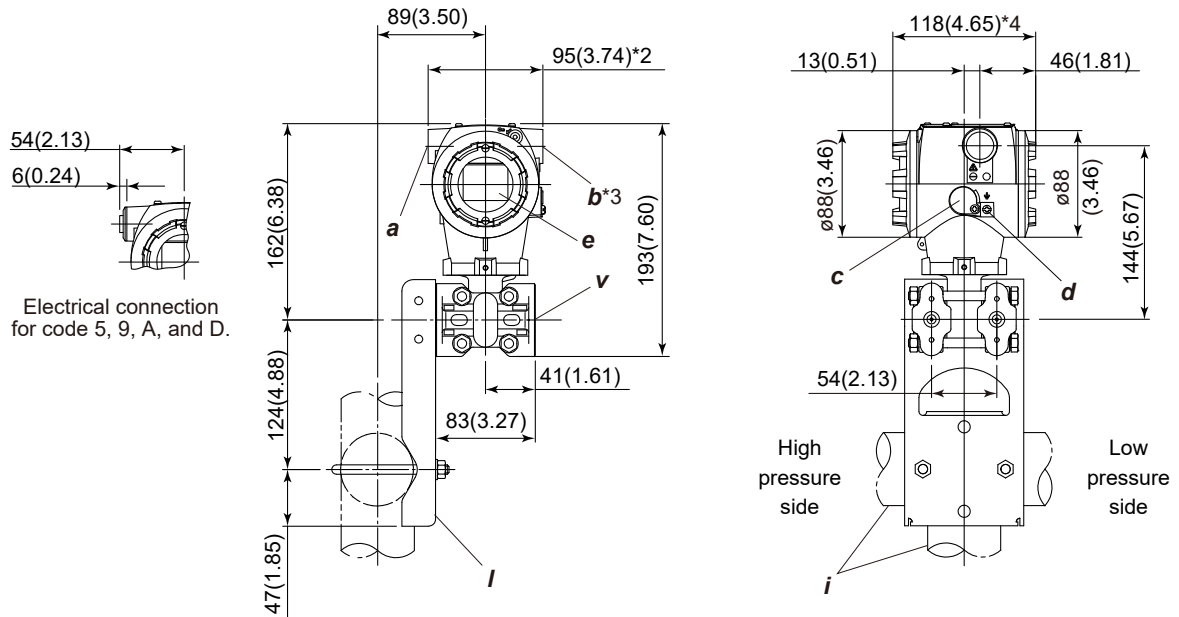

a	External indicator Conduit connection (optional)	d	Ground terminal	i	Mounting bracket (Flat-type, optional)
b	Conduit connection	e	Display (optional)	v	Threads for diaphragm seal
c	Zero adjustment	i	2-inch pipe (O.D. 60.5 mm)		

- *1: Process connection code W is for combination with the third party's diaphragm seal.
- *2: In case of electrical connection code 7 or C is specified, a blind plug is protruded by up to 8 mm (0.31 inch) from conduit connection.
- *3: In case of optional code /PP specified, a blind plug is attached to conduit connection on both sides.
- *4: In case of Display and interface code N specified, it is 113 mm (4.45 inch).

● Option Code /N1

Unit: mm (approx.inch)

- Wetted Parts Material Code: S, F, G and Capsule Range Code: M, H, V

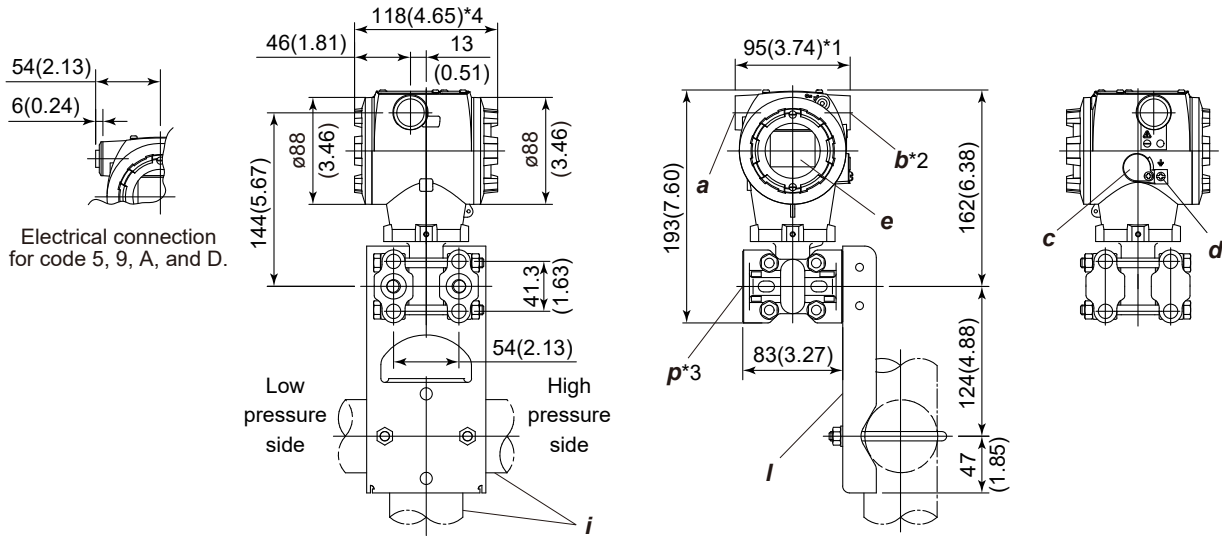

- Wetted Parts Material Code: H, M, T or Capsule Range Code: F, J, K, P, Q

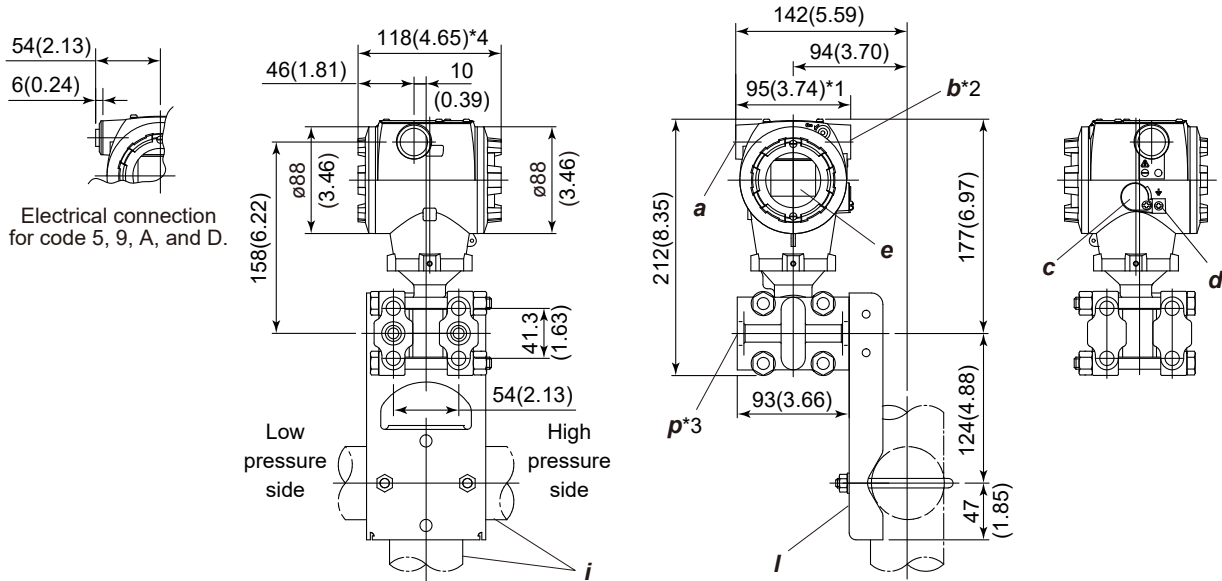

a	External indicator Conduit connection (optional)	e	Display (optional)
b	Conduit connection	i	2-inch pipe (O.D. 60.5 mm)
c	Zero adjustment	l	Mounting bracket (Flat-type, optional)
d	Ground terminal	p	Process connection

Unit: mm (approx.inch)

● Capsule Range Code: E

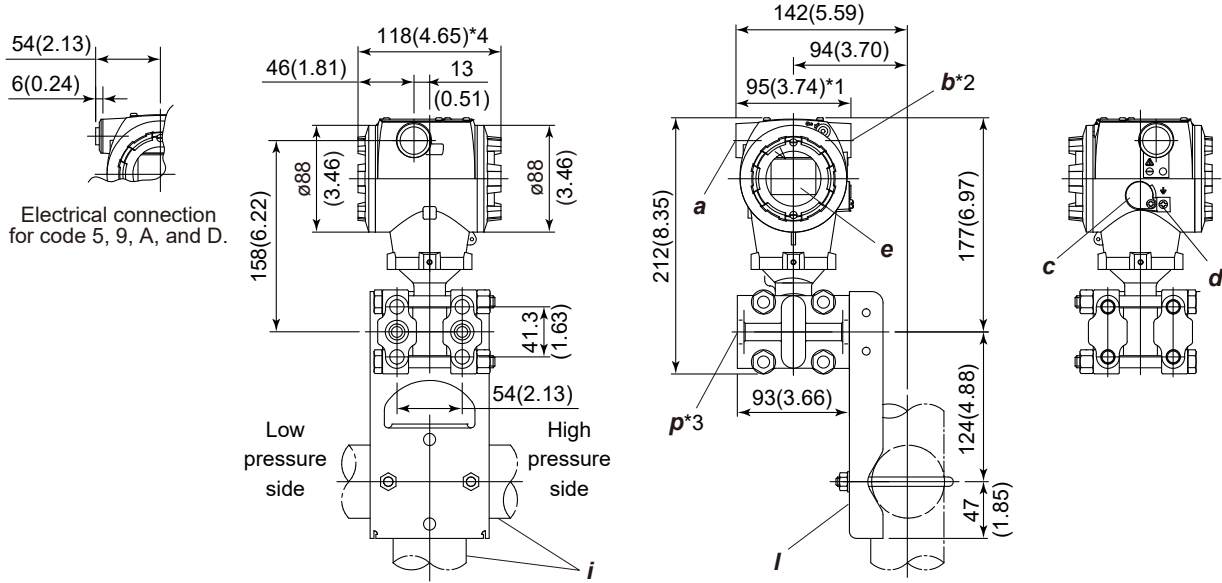

● Capsule Range Code: 1, 2, 3, 5, 6 and Bolts and Nuts Material Code: D, F, L

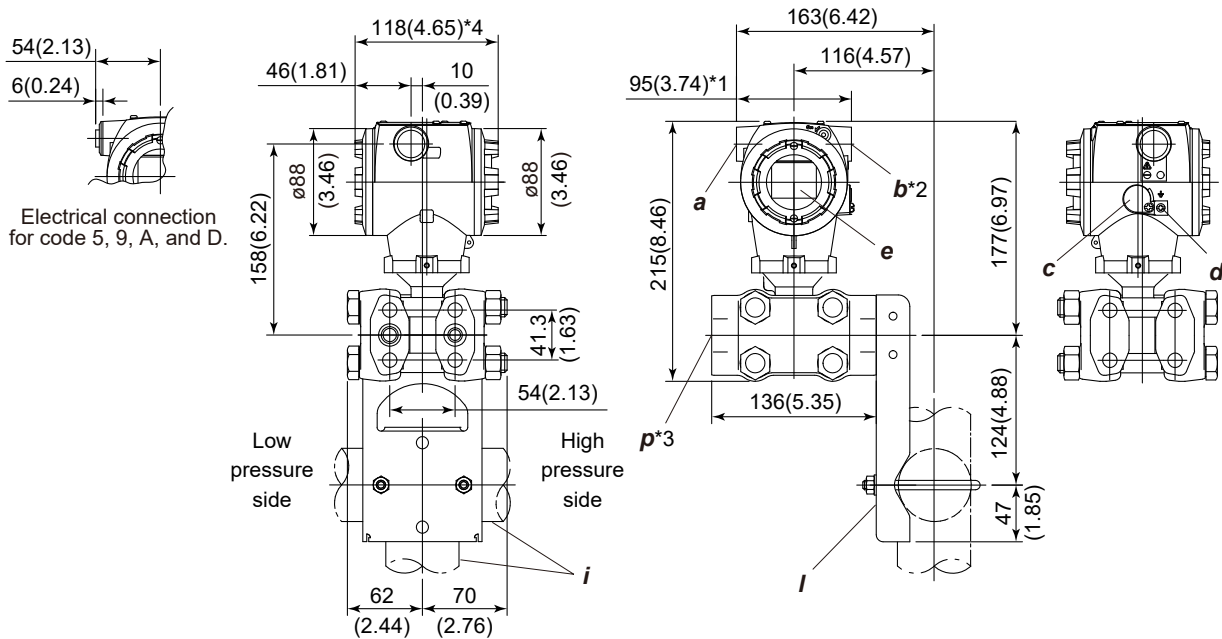

a	External indicator Conduit connection (optional)	e	Display (optional)
b	Conduit connection	i	2-inch pipe (O.D. 60.5 mm)
c	Zero adjustment	l	Mounting bracket (Flat-type, optional)
d	Ground terminal	p	Process connection

Unit: mm (approx.inch)

- Capsule Range Code: 1, 2, 3, 5, 6 and Bolts and Nuts Material Code: K, H

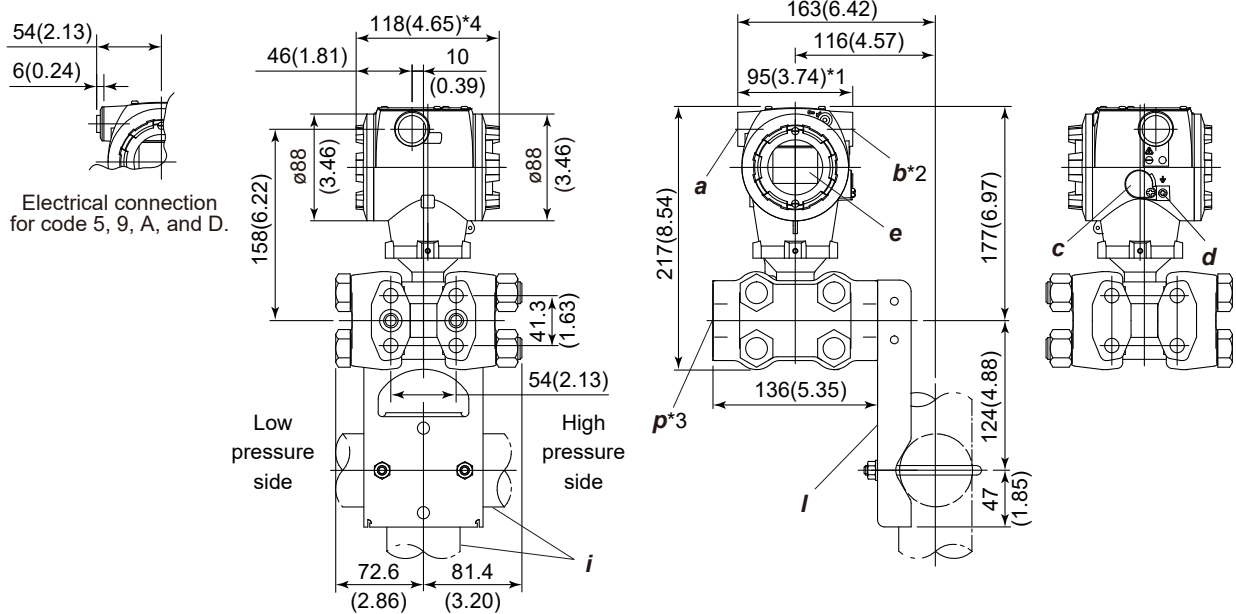

a	External indicator Conduit connection (optional)	e	Display (optional)
b	Conduit connection	i	2-inch pipe (O.D. 60.5 mm)
c	Zero adjustment	l	Mounting bracket (Flat-type, optional)
d	Ground terminal	p	Process connection

- *1: In case of electrical connection code 7 or C is specified, a blind plug is protruded by up to 8 mm (0.31 inch) from conduit connection.
- *2: In case of optional code /PP specified, a blind plug is attached to conduit connection on both sides.
- *3: In case of optional code /BS specified, a bug screen is installed to the process connection port of the low side cover flange.
- *4: In case of Display and interface code N specified, it is 113 mm (4.45 inch).

● Option Code /N2 and /N3

Unit: mm (approx.inch)

- Wetted Parts Material Code: S, F, G and Capsule Range Code: M, H, V

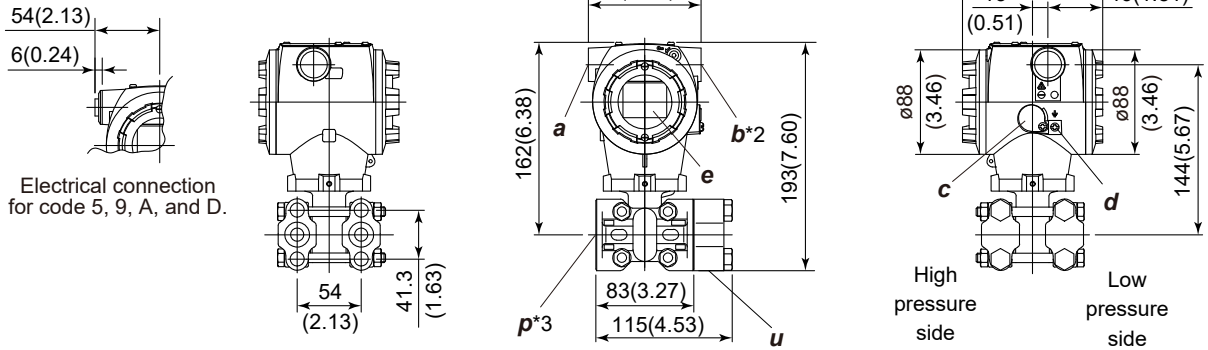

- Wetted Parts Material Code: H, M, T or Capsule Range Code: F, J, K, P, Q

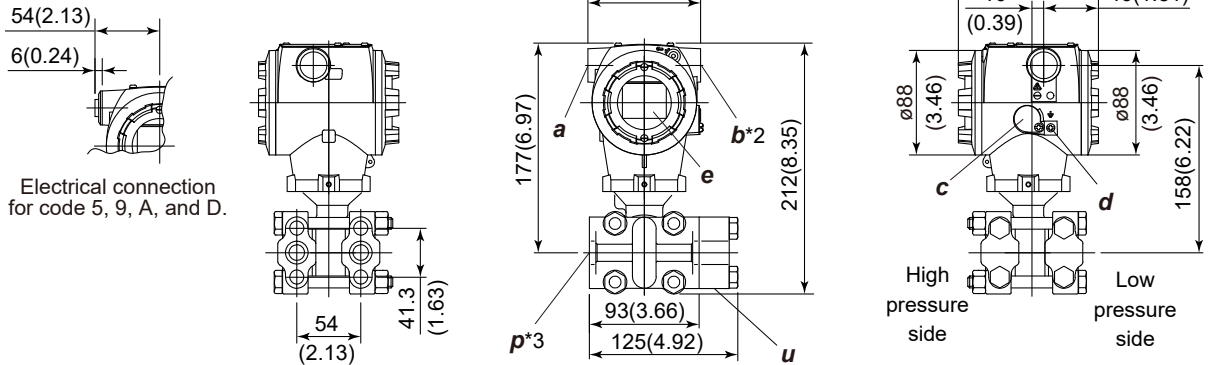

- Capsule Range Code: E

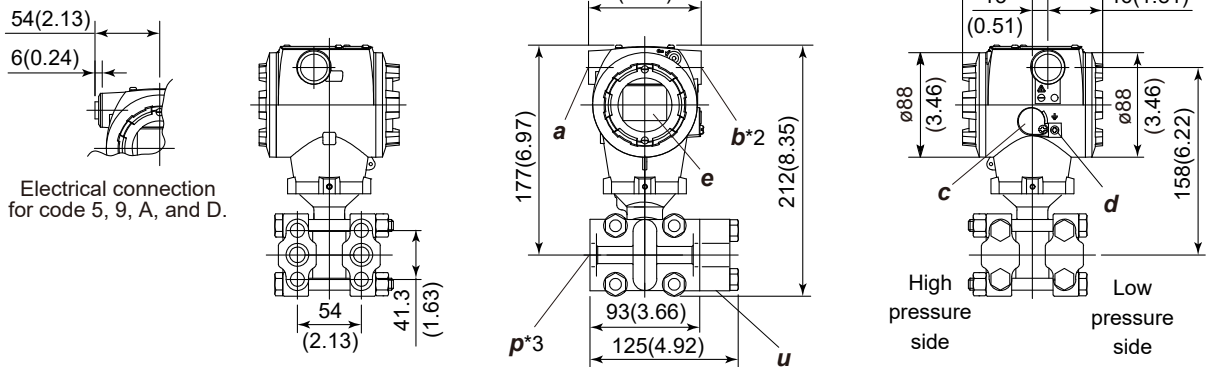

a	External indicator Conduit connection (optional)	e	Display (optional)
b	Conduit connection	p	Process connection
c	Zero adjustment	u	Blind kidney flange
d	Ground terminal		

Unit: mm (approx.inch)

- Capsule Range Code: 1, 2, 3, 5, 6 and Bolts and Nuts Material Code: D, F, L

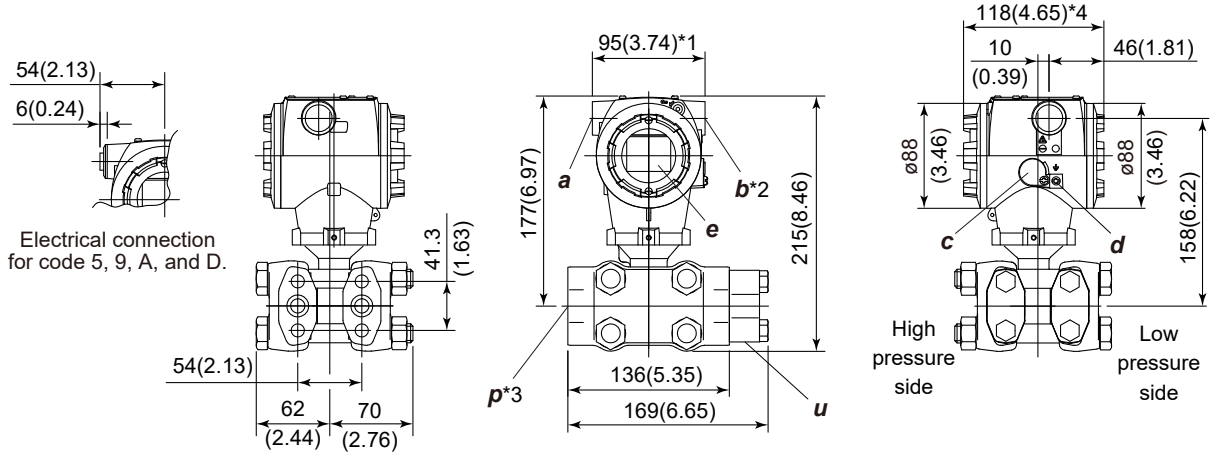

- Capsule Range Code: 1, 2, 3, 5, 6 and Bolts and Nuts Material Code: K, H

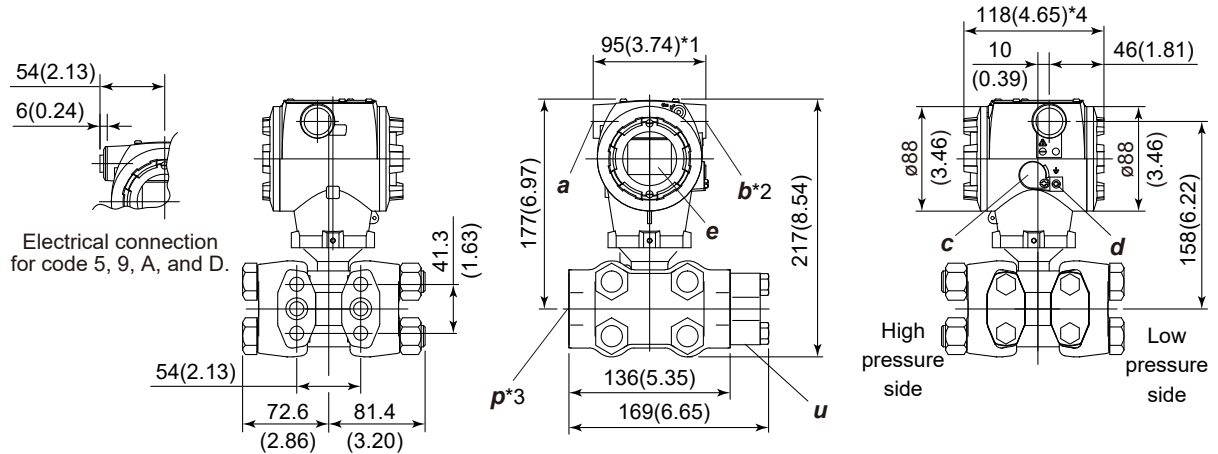

a	External indicator Conduit connection (optional)	e	Display (optional)
b	Conduit connection	p	Process connection
c	Zero adjustment	u	Blind kidney flange
d	Ground terminal		

*1: In case of electrical connection code 7 or C is specified, a blind plug is protruded by up to 8 mm (0.31 inch) from conduit connection.

*2: In case of optional code /PP specified, a blind plug is attached to conduit connection on both sides.

*3: In case of optional code /BS specified, a bug screen is installed to the process connection port of the low side cover flange.

*4: In case of Display and interface code N specified, it is 113 mm (4.45 inch).

• Terminal Configuration

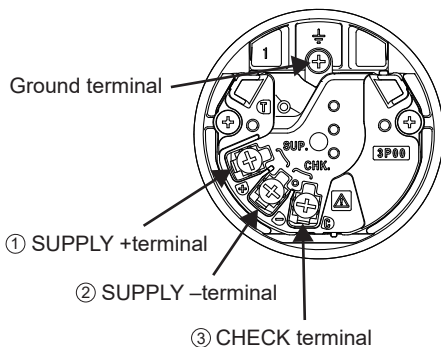

• Terminal Wiring

SUPPLY +	①	Power supply and output terminals
-	②	
CHECK +	③	External indicator (ammeter) terminals *1
-	②	
		⏏ Ground terminal

*1: When using an external indicator or check meter, the internal resistance must be 10Ω or less. Not available for PROFINET communication type.

■ EXPLOSION PROTECTED TYPE

Item	Code	Description																
Canadian Standards Association (CSA)	-CF1	Canada Flameproof Enclosure/ Dust ignition protection by enclosure																
		Zone Certificate: FM25CA0015X																
		Applicable standard: CSA C22.2 No. 60079-0, CSA C22.2 No. 60079-1, CSA C22.2 No. 60079-31, CSA C22.2 No. 61010-1-12																
		Marking: Flameproof Approval: Ex db IIC T6...T4 Gb Dust-ignition protection by enclosure Approval: Ex tb IIIC T85°C Db																
		Ambient and Process temperature																
		<table border="1"> <thead> <tr> <th>Type</th> <th>output</th> <th>Temperature class</th> <th>Ambient Temperature</th> <th>Process Temperature</th> </tr> </thead> <tbody> <tr> <td rowspan="3">Gas</td> <td rowspan="3">-</td> <td>T6</td> <td>-60°C≤Ta≤+75°C</td> <td>-60°C≤Tp≤+80°C</td> </tr> <tr> <td>T5</td> <td>-60°C≤Ta≤+80°C</td> <td>-60°C≤Tp≤+95°C</td> </tr> <tr> <td>T4</td> <td>-60°C≤Ta≤+75°C</td> <td>-60°C≤Tp≤+120°C</td> </tr> </tbody> </table>	Type	output	Temperature class	Ambient Temperature	Process Temperature	Gas	-	T6	-60°C≤Ta≤+75°C	-60°C≤Tp≤+80°C	T5	-60°C≤Ta≤+80°C	-60°C≤Tp≤+95°C	T4	-60°C≤Ta≤+75°C	-60°C≤Tp≤+120°C
		Type	output	Temperature class	Ambient Temperature	Process Temperature												
		Gas	-	T6	-60°C≤Ta≤+75°C	-60°C≤Tp≤+80°C												
				T5	-60°C≤Ta≤+80°C	-60°C≤Tp≤+95°C												
				T4	-60°C≤Ta≤+75°C	-60°C≤Tp≤+120°C												
<table border="1"> <thead> <tr> <th>Type</th> <th>output</th> <th>Maximum surface Temperature</th> <th>Ambient Temperature</th> <th>Process Temperature</th> </tr> </thead> <tbody> <tr> <td>Dust</td> <td>-</td> <td>T85°C</td> <td>-40°C≤Ta≤+75°C</td> <td>-40°C≤Tp≤+80°C</td> </tr> </tbody> </table>	Type	output	Maximum surface Temperature	Ambient Temperature	Process Temperature	Dust	-	T85°C	-40°C≤Ta≤+75°C	-40°C≤Tp≤+80°C								
Type	output	Maximum surface Temperature	Ambient Temperature	Process Temperature														
Dust	-	T85°C	-40°C≤Ta≤+75°C	-40°C≤Tp≤+80°C														
Division Certificate: FM25CA0015X																		
Applicable standard: CSA C22.2 No. 25, CSA C22.2 No. 30, CSA C22.2 No. 94.2, CSA C22.2 No. 60079-40																		
Marking: Explosionproof Approval: Class I, Division 1, Groups B, C and D; Temperature class: T6...T4 Dust-Ignitionproof Approval: Class II/III, Division 1, Groups E, F and G; Temperature class: T6																		
Ambient and Process temperature																		
<table border="1"> <thead> <tr> <th>Type</th> <th>output</th> <th>Temperature class</th> <th>Ambient Temperature</th> <th>Process Temperature</th> </tr> </thead> <tbody> <tr> <td rowspan="3">Gas</td> <td rowspan="3">-</td> <td>T6</td> <td>-50°C≤Ta≤+75°C</td> <td>-50°C≤Tp≤+80°C</td> </tr> <tr> <td>T5</td> <td rowspan="2">-50°C≤Ta≤+80°C</td> <td>-50°C≤Tp≤+95°C</td> </tr> <tr> <td>T4</td> <td>-50°C≤Tp≤+130°C</td> </tr> </tbody> </table>	Type	output	Temperature class	Ambient Temperature	Process Temperature	Gas	-	T6	-50°C≤Ta≤+75°C	-50°C≤Tp≤+80°C	T5	-50°C≤Ta≤+80°C	-50°C≤Tp≤+95°C	T4	-50°C≤Tp≤+130°C			
Type	output	Temperature class	Ambient Temperature	Process Temperature														
Gas	-	T6	-50°C≤Ta≤+75°C	-50°C≤Tp≤+80°C														
		T5	-50°C≤Ta≤+80°C	-50°C≤Tp≤+95°C														
		T4		-50°C≤Tp≤+130°C														
<table border="1"> <thead> <tr> <th>Type</th> <th>output</th> <th>Maximum surface Temperature</th> <th>Ambient Temperature</th> <th>Process Temperature</th> </tr> </thead> <tbody> <tr> <td>Dust</td> <td>-</td> <td>T6</td> <td>-40°C≤Ta≤+75°C</td> <td>-40°C≤Tp≤+80°C</td> </tr> </tbody> </table>	Type	output	Maximum surface Temperature	Ambient Temperature	Process Temperature	Dust	-	T6	-40°C≤Ta≤+75°C	-40°C≤Tp≤+80°C								
Type	output	Maximum surface Temperature	Ambient Temperature	Process Temperature														
Dust	-	T6	-40°C≤Ta≤+75°C	-40°C≤Tp≤+80°C														
Factory Sealed: CONDUIT SEAL NOT REQUIRED																		
Process Seal: Dual Seal Without Annunciation (up to 50 MPa)																		
Explosionproof MWP: 50 MPa																		

Item	Code	Description																																											
Canadian Standards Association (CSA)	-CS1	<p>Canada Intrinsically safe</p> <p>Output signal Code:J HART</p> <p>Intrinsically safe approval Certificate: FM25CA0015X</p> <p>Applicable standard: CSA C22.2 No.0 C22.2 No. 94.2, C22.2 No.213, C22.2 No. 60079-0 CSA-C22.2 No. 60079-11, CSA-C22.2 No. 61010-1-12, CSA C22.2 No. 60079-40</p> <p>Marking: IS Class I, Division 1, Groups A, B, C, D; Class II, Division 1, Groups E, F, G; Class III, Division 1; Temperature Code: T5...T4 Ex ia IIC T5...T4 Ga</p> <p>Ambient and Process temperature</p> <table border="1"> <thead> <tr> <th>Type</th> <th>output</th> <th>Temperature class</th> <th>Ambient temperature</th> <th>Process temperature</th> </tr> </thead> <tbody> <tr> <td rowspan="2">Gas</td> <td rowspan="2">-J</td> <td>T5</td> <td>-55°C≤Ta≤+40°C</td> <td>Tp≤+95°C</td> </tr> <tr> <td>T4</td> <td>-55°C≤Ta≤+60°C</td> <td>Tp≤+120°C</td> </tr> </tbody> </table> <table border="1"> <thead> <tr> <th>Type</th> <th>output</th> <th>Maximum surface temperature</th> <th>Ambient temperature</th> <th>Process temperature</th> </tr> </thead> <tbody> <tr> <td rowspan="3">Dust</td> <td rowspan="3">-</td> <td>T85°C</td> <td rowspan="3">-40°C≤Ta≤+60°C</td> <td>Tp≤+80°C</td> </tr> <tr> <td>T100°C</td> <td>Tp≤+95°C</td> </tr> <tr> <td>T120°C</td> <td>Tp≤+115°C</td> </tr> </tbody> </table> <p>Electrical parameter: Ui=30 V, Ii=200 mA, Pi=1.0 W, Ci=22 nF, Li=0 mH</p> <p>Non-incendive approval Certificate: FM25CA0015X</p> <p>Applicable standard: CSA C22.2 No.0 C22.2 No. 94.2, C22.2 No.213, C22.2 No. 60079-0 CSA-C22.2 No. 60079-11, CSA-C22.2 No. 61010-1-12, CSA C22.2 No. 60079-40</p> <p>Marking: NIFW Class I, Division 2, Groups A, B, C, D; Class II, Division 2, Groups F, G; Class III, Division 1; Temperature Code: T6...T4 CL I Zone 2, Group IIC T6...T4</p> <p>Ambient and Process temperature</p> <table border="1"> <thead> <tr> <th>Type</th> <th>output</th> <th>Temperature class</th> <th>Ambient Temperature</th> <th>Process Temperature</th> </tr> </thead> <tbody> <tr> <td rowspan="3">Gas Dust</td> <td rowspan="3">-J</td> <td>T6</td> <td>-40°C≤Ta≤+53°C</td> <td>-40°C≤Tp≤+80°C</td> </tr> <tr> <td>T5</td> <td>-40°C≤Ta≤+66°C</td> <td>-40°C≤Tp≤+95°C</td> </tr> <tr> <td>T4</td> <td>-40°C≤Ta≤+80°C</td> <td>-40°C≤Tp≤+130°C</td> </tr> </tbody> </table> <p>Electrical parameter Ui=42 V, Ci=22 nF, Li=0 mH</p>	Type	output	Temperature class	Ambient temperature	Process temperature	Gas	-J	T5	-55°C≤Ta≤+40°C	Tp≤+95°C	T4	-55°C≤Ta≤+60°C	Tp≤+120°C	Type	output	Maximum surface temperature	Ambient temperature	Process temperature	Dust	-	T85°C	-40°C≤Ta≤+60°C	Tp≤+80°C	T100°C	Tp≤+95°C	T120°C	Tp≤+115°C	Type	output	Temperature class	Ambient Temperature	Process Temperature	Gas Dust	-J	T6	-40°C≤Ta≤+53°C	-40°C≤Tp≤+80°C	T5	-40°C≤Ta≤+66°C	-40°C≤Tp≤+95°C	T4	-40°C≤Ta≤+80°C	-40°C≤Tp≤+130°C
	Type	output	Temperature class	Ambient temperature	Process temperature																																								
Gas	-J	T5	-55°C≤Ta≤+40°C	Tp≤+95°C																																									
		T4	-55°C≤Ta≤+60°C	Tp≤+120°C																																									
Type	output	Maximum surface temperature	Ambient temperature	Process temperature																																									
Dust	-	T85°C	-40°C≤Ta≤+60°C	Tp≤+80°C																																									
		T100°C		Tp≤+95°C																																									
		T120°C		Tp≤+115°C																																									
Type	output	Temperature class	Ambient Temperature	Process Temperature																																									
Gas Dust	-J	T6	-40°C≤Ta≤+53°C	-40°C≤Tp≤+80°C																																									
		T5	-40°C≤Ta≤+66°C	-40°C≤Tp≤+95°C																																									
		T4	-40°C≤Ta≤+80°C	-40°C≤Tp≤+130°C																																									
-CU1	Multiple type of protection (CF1 or CS1)																																												

Item	Code	Description																
FM explosion protection (USA)	-FF1	USA Flameproof Enclosure/ Dust ignition protection by enclosure																
		Zone Certificate: FM25US0031X																
		Applicable standard: ANSI/UL 60079-0, ANSI/UL 60079-1, ANSI/UL 60079-31, ANSI/UL 61010-1																
		Marking: Flameproof Approval: Zone 1, AEx db IIC T6...T4 Gb Dust-ignition protection by enclosure Approval: Zone 21, AEx tb IIIC T85°C Db																
		Ambient and Process temperature																
		<table border="1"> <thead> <tr> <th>Type</th> <th>output</th> <th>Temperature class</th> <th>Ambient Temperature</th> <th>Process Temperature</th> </tr> </thead> <tbody> <tr> <td rowspan="3">Gas</td> <td rowspan="3">-</td> <td>T6</td> <td>-50°C≤Ta≤+75°C</td> <td>-60°C≤Tp≤+80°C</td> </tr> <tr> <td>T5</td> <td>-50°C≤Ta≤+80°C</td> <td>-60°C≤Tp≤+95°C</td> </tr> <tr> <td>T4</td> <td>-50°C≤Ta≤+75°C</td> <td>-60°C≤Tp≤+120°C</td> </tr> </tbody> </table>	Type	output	Temperature class	Ambient Temperature	Process Temperature	Gas	-	T6	-50°C≤Ta≤+75°C	-60°C≤Tp≤+80°C	T5	-50°C≤Ta≤+80°C	-60°C≤Tp≤+95°C	T4	-50°C≤Ta≤+75°C	-60°C≤Tp≤+120°C
		Type	output	Temperature class	Ambient Temperature	Process Temperature												
		Gas	-	T6	-50°C≤Ta≤+75°C	-60°C≤Tp≤+80°C												
				T5	-50°C≤Ta≤+80°C	-60°C≤Tp≤+95°C												
				T4	-50°C≤Ta≤+75°C	-60°C≤Tp≤+120°C												
		<table border="1"> <thead> <tr> <th>Type</th> <th>output</th> <th>Maximum surface Temperature</th> <th>Ambient Temperature</th> <th>Process Temperature</th> </tr> </thead> <tbody> <tr> <td>Dust</td> <td>-</td> <td>T85°C</td> <td>-40°C≤Ta≤+75°C</td> <td>-40°C≤Tp≤+80°C</td> </tr> </tbody> </table>	Type	output	Maximum surface Temperature	Ambient Temperature	Process Temperature	Dust	-	T85°C	-40°C≤Ta≤+75°C	-40°C≤Tp≤+80°C						
		Type	output	Maximum surface Temperature	Ambient Temperature	Process Temperature												
Dust	-	T85°C	-40°C≤Ta≤+75°C	-40°C≤Tp≤+80°C														
Division Certificate: FM25US0031X																		
Applicable standard: FM 3600, FM 3615, FM 3616, FM 3810, ANSI/UL 50E, ANSI/UL 122701																		
Marking: Explosionproof Approval: Class I, Division 1, Groups B, C and D; Temperature class: T6...T4 Dust-Ignitionproof Approval: Class II/III, Division 1, Groups E, F and G; Temperature class: T6																		
Enclosure: Type 4X																		
Ambient and Process temperature																		
<table border="1"> <thead> <tr> <th>Type</th> <th>output</th> <th>Temperature class</th> <th>Ambient Temperature</th> <th>Process Temperature</th> </tr> </thead> <tbody> <tr> <td rowspan="3">Gas</td> <td rowspan="3">-</td> <td>T6</td> <td>-40°C≤Ta≤+75°C</td> <td>-40°C≤Tp≤+80°C</td> </tr> <tr> <td>T5</td> <td>-40°C≤Ta≤+80°C</td> <td>-40°C≤Tp≤+95°C</td> </tr> <tr> <td>T4</td> <td>-40°C≤Ta≤+80°C</td> <td>-40°C≤Tp≤+130°C</td> </tr> </tbody> </table>	Type	output	Temperature class	Ambient Temperature	Process Temperature	Gas	-	T6	-40°C≤Ta≤+75°C	-40°C≤Tp≤+80°C	T5	-40°C≤Ta≤+80°C	-40°C≤Tp≤+95°C	T4	-40°C≤Ta≤+80°C	-40°C≤Tp≤+130°C		
Type	output	Temperature class	Ambient Temperature	Process Temperature														
Gas	-	T6	-40°C≤Ta≤+75°C	-40°C≤Tp≤+80°C														
		T5	-40°C≤Ta≤+80°C	-40°C≤Tp≤+95°C														
		T4	-40°C≤Ta≤+80°C	-40°C≤Tp≤+130°C														
<table border="1"> <thead> <tr> <th>Type</th> <th>output</th> <th>Maximum surface Temperature</th> <th>Ambient Temperature</th> <th>Process Temperature</th> </tr> </thead> <tbody> <tr> <td>Dust</td> <td>-</td> <td>T6</td> <td>-40°C≤Ta≤+75°C</td> <td>-40°C≤Tp≤+80°C</td> </tr> </tbody> </table>	Type	output	Maximum surface Temperature	Ambient Temperature	Process Temperature	Dust	-	T6	-40°C≤Ta≤+75°C	-40°C≤Tp≤+80°C								
Type	output	Maximum surface Temperature	Ambient Temperature	Process Temperature														
Dust	-	T6	-40°C≤Ta≤+75°C	-40°C≤Tp≤+80°C														
Factory Sealed: CONDUIT SEAL NOT REQUIRED																		
Process Seal: Dual Seal Without Annunciation (up to 50 MPa)																		

Item	Code	Description																																											
FM explosion protection (USA)	-FS1	USA intrinsically safe																																											
		<p>Output signal Code: J HART</p> <p>Intrinsically safe approval Certificate: FM25US0031X</p> <p>Applicable standard: FM 3600, FM 3610, FM 3611, FM 3810, ANSI/UL 60079-0, ANSI/UL 60079-11, UL 60079-47, ANSI/UL 61010-1, ANSI/UL 121201, ANSI/UL 122701, ANSI/UL 50E</p> <p>Marking: IS Class I, Division 1, Groups A, B, C, D; Class II, Division 1, Groups E, F, G; Class III, Division 1; Temperature Code: T5...T4 CL I Zone 0, AEx ia IIC T5...T4 Ga</p> <p>Enclosure: Type 4X</p> <p>Ambient and Process temperature</p> <table border="1"> <thead> <tr> <th>Type</th> <th>output</th> <th>Temperature class</th> <th>Ambient temperature</th> <th>Process temperature</th> </tr> </thead> <tbody> <tr> <td rowspan="2">Gas</td> <td rowspan="2">-J</td> <td>T5</td> <td>-55°C≤Ta≤+40°C</td> <td>Tp≤+95°C</td> </tr> <tr> <td>T4</td> <td>-55°C≤Ta≤+60°C</td> <td>Tp≤+120°C</td> </tr> </tbody> </table> <table border="1"> <thead> <tr> <th>Type</th> <th>output</th> <th>Maximum surface temperature</th> <th>Ambient temperature</th> <th>Process temperature</th> </tr> </thead> <tbody> <tr> <td rowspan="3">Dust</td> <td rowspan="3">-</td> <td>T85°C</td> <td rowspan="3">-40°C≤Ta≤+60°C</td> <td>Tp≤+80°C</td> </tr> <tr> <td>T100°C</td> <td>Tp≤+95°C</td> </tr> <tr> <td>T120°C</td> <td>Tp≤+115°C</td> </tr> </tbody> </table> <p>Electrical parameter: Ui=30 V, li=200 mA, Pi=1.0 W, Ci=22 nF, Li=0 mH</p> <p>Non-incendive approval Certificate: FM25US0031X</p> <p>Applicable standard: FM 3600, FM 3610, FM 3611, FM 3810, ANSI/UL 60079-0, ANSI/UL 60079-11, ANSI/UL 61010-1, ANSI/UL 121201, ANSI/UL 122701, ANSI/UL 50E</p> <p>Marking: NIFW Class I, Division 2, Groups A, B, C, D; Class II, Division 2, Groups F, G; Class III, Division 1; Temperature Code: T6...T4 CL I Zone 2, Group IIC T6...T4</p> <p>Enclosure: Type 4X</p> <p>Ambient and Process temperature</p> <table border="1"> <thead> <tr> <th>Type</th> <th>output</th> <th>Temperature class</th> <th>Ambient Temperature</th> <th>Process Temperature</th> </tr> </thead> <tbody> <tr> <td rowspan="2">Gas</td> <td rowspan="2">-J</td> <td>T6</td> <td>-40°C≤Ta≤+53°C</td> <td>-40°C≤Tp≤+80°C</td> </tr> <tr> <td>T5</td> <td>-40°C≤Ta≤+66°C</td> <td>-40°C≤Ta≤+95°C</td> </tr> <tr> <td>Dust</td> <td>-</td> <td>T4</td> <td>-40°C≤Ta≤+80°C</td> <td>-40°C≤Tp≤+130°C</td> </tr> </tbody> </table> <p>Electrical parameter: Ui=42 V, Ci=22 nF, Li=0 mH</p>	Type	output	Temperature class	Ambient temperature	Process temperature	Gas	-J	T5	-55°C≤Ta≤+40°C	Tp≤+95°C	T4	-55°C≤Ta≤+60°C	Tp≤+120°C	Type	output	Maximum surface temperature	Ambient temperature	Process temperature	Dust	-	T85°C	-40°C≤Ta≤+60°C	Tp≤+80°C	T100°C	Tp≤+95°C	T120°C	Tp≤+115°C	Type	output	Temperature class	Ambient Temperature	Process Temperature	Gas	-J	T6	-40°C≤Ta≤+53°C	-40°C≤Tp≤+80°C	T5	-40°C≤Ta≤+66°C	-40°C≤Ta≤+95°C	Dust	-	T4
Type	output	Temperature class	Ambient temperature	Process temperature																																									
Gas	-J	T5	-55°C≤Ta≤+40°C	Tp≤+95°C																																									
		T4	-55°C≤Ta≤+60°C	Tp≤+120°C																																									
Type	output	Maximum surface temperature	Ambient temperature	Process temperature																																									
Dust	-	T85°C	-40°C≤Ta≤+60°C	Tp≤+80°C																																									
		T100°C		Tp≤+95°C																																									
		T120°C		Tp≤+115°C																																									
Type	output	Temperature class	Ambient Temperature	Process Temperature																																									
Gas	-J	T6	-40°C≤Ta≤+53°C	-40°C≤Tp≤+80°C																																									
		T5	-40°C≤Ta≤+66°C	-40°C≤Ta≤+95°C																																									
Dust	-	T4	-40°C≤Ta≤+80°C	-40°C≤Tp≤+130°C																																									

Item	Code	Description																													
FM explosion protection (USA)	-FS1	Output signal Code:T PROFINET	Certificate: FM25US0031X Applicable standard: FM 3600, FM 3610, FM 3611, FM 3810, ANSI/UL 60079-0, ANSI/UL 60079-11, UL 60079-47, ANSI/UL 61010-1, ANSI/UL 121201, ANSI/UL 122701, ANSI/UL 50E Marking: IS Class I, Division 1, Groups A, B, C, D; Class II, Division 1, Groups E, F, G; Class III, Division 1; Temperature Code: T5...T4 CL I Zone 0, AEx ia IIC T5...T4 Ga Enclosure: Type 4X Ambient and Process temperature <table border="1"> <thead> <tr> <th>Type</th> <th>output</th> <th>Temperature class</th> <th>Ambient temperature</th> <th>Process temperature</th> </tr> </thead> <tbody> <tr> <td rowspan="2">Gas</td> <td rowspan="2">-T</td> <td>T5</td> <td>-40°C≤Ta≤+40°C</td> <td>Tp≤+95°C</td> </tr> <tr> <td>T4</td> <td>-40°C≤Ta≤+60°C</td> <td>Tp≤+120°C</td> </tr> </tbody> </table> <table border="1"> <thead> <tr> <th>Type</th> <th>output</th> <th>Maximum surface temperature</th> <th>Ambient temperature</th> <th>Process temperature</th> </tr> </thead> <tbody> <tr> <td rowspan="3">Dust</td> <td rowspan="3">-</td> <td>T85°C</td> <td rowspan="3">-40°C≤Ta≤+60°C</td> <td>Tp≤+80°C</td> </tr> <tr> <td>T100°C</td> <td>Tp≤+95°C</td> </tr> <tr> <td>T120°C</td> <td>Tp≤+115°C</td> </tr> </tbody> </table> Electrical parameter: 2-WISE power load		Type	output	Temperature class	Ambient temperature	Process temperature	Gas	-T	T5	-40°C≤Ta≤+40°C	Tp≤+95°C	T4	-40°C≤Ta≤+60°C	Tp≤+120°C	Type	output	Maximum surface temperature	Ambient temperature	Process temperature	Dust	-	T85°C	-40°C≤Ta≤+60°C	Tp≤+80°C	T100°C	Tp≤+95°C	T120°C	Tp≤+115°C
	Type	output	Temperature class	Ambient temperature	Process temperature																										
Gas	-T	T5	-40°C≤Ta≤+40°C	Tp≤+95°C																											
		T4	-40°C≤Ta≤+60°C	Tp≤+120°C																											
Type	output	Maximum surface temperature	Ambient temperature	Process temperature																											
Dust	-	T85°C	-40°C≤Ta≤+60°C	Tp≤+80°C																											
		T100°C		Tp≤+95°C																											
		T120°C		Tp≤+115°C																											
-FU1	Multiple type of protection (FF1 or FS1)																														
ATEX	-KF1	ATEX Flameproof Enclosure/ Dust ignition protection by enclosure Certificate: FM25ATEX0009X Applicable standard: EN IEC 60079-0, EN 60079-1, EN 60079-31 Marking: Flameproof Approval: II 2 G Ex db IIC T6...T4 Gb Dust-Ignitionproof Approval: II 2 D Ex tb IIIC T85°C Db Ambient and Process temperature <table border="1"> <thead> <tr> <th>Type</th> <th>output</th> <th>Temperature class</th> <th>Ambient Temperature</th> <th>Process Temperature</th> </tr> </thead> <tbody> <tr> <td rowspan="3">Gas</td> <td rowspan="3">-</td> <td>T6</td> <td>-60°C≤Ta≤+75°C</td> <td>-60°C≤Tp≤+80°C</td> </tr> <tr> <td>T5</td> <td>-60°C≤Ta≤+80°C</td> <td>-60°C≤Tp≤+95°C</td> </tr> <tr> <td>T4</td> <td>-60°C≤Ta≤+75°C</td> <td>-60°C≤Tp≤+120°C</td> </tr> </tbody> </table> <table border="1"> <thead> <tr> <th>Type</th> <th>output</th> <th>Maximum surface Temperature</th> <th>Ambient Temperature</th> <th>Process Temperature</th> </tr> </thead> <tbody> <tr> <td>Dust</td> <td>-</td> <td>T85°C</td> <td>-40°C≤Ta≤+75°C</td> <td>-40°C≤Tp≤+80°C</td> </tr> </tbody> </table>			Type	output	Temperature class	Ambient Temperature	Process Temperature	Gas	-	T6	-60°C≤Ta≤+75°C	-60°C≤Tp≤+80°C	T5	-60°C≤Ta≤+80°C	-60°C≤Tp≤+95°C	T4	-60°C≤Ta≤+75°C	-60°C≤Tp≤+120°C	Type	output	Maximum surface Temperature	Ambient Temperature	Process Temperature	Dust	-	T85°C	-40°C≤Ta≤+75°C	-40°C≤Tp≤+80°C	
	Type	output	Temperature class	Ambient Temperature	Process Temperature																										
Gas	-	T6	-60°C≤Ta≤+75°C	-60°C≤Tp≤+80°C																											
		T5	-60°C≤Ta≤+80°C	-60°C≤Tp≤+95°C																											
		T4	-60°C≤Ta≤+75°C	-60°C≤Tp≤+120°C																											
Type	output	Maximum surface Temperature	Ambient Temperature	Process Temperature																											
Dust	-	T85°C	-40°C≤Ta≤+75°C	-40°C≤Tp≤+80°C																											

Item	Code	Description																																						
ATEX	-KS1	ATEX intrinsically safe																																						
		<p>Output signal Code:J HART</p> <p>Intrinsically safe ia Certificate: FM25ATEX0009X</p> <p>Applicable standard: EN IEC 60079-0, EN 60079-11</p> <p>Marking: II 1 G Ex ia IIC T5...T4 Ga, II 2 D Ex ia IIIC T85°C...T120°C Db, II 3 G Ex ic IIC T5...T4 Gc</p> <p>Ambient and Process temperature</p> <table border="1"> <thead> <tr> <th>Type</th> <th>output</th> <th>Temperature class</th> <th>Ambient temperature</th> <th>Process temperature</th> </tr> </thead> <tbody> <tr> <td rowspan="2">Gas</td> <td rowspan="2">-J</td> <td>T5</td> <td>-55°C≤Ta≤+40°C</td> <td>Tp≤+95°C</td> </tr> <tr> <td>T4</td> <td>-55°C≤Ta≤+60°C</td> <td>Tp≤+120°C</td> </tr> </tbody> </table> <table border="1"> <thead> <tr> <th>Type</th> <th>output</th> <th>Maximum surface temperature</th> <th>Ambient temperature</th> <th>Process temperature</th> </tr> </thead> <tbody> <tr> <td rowspan="3">Dust</td> <td rowspan="3">-</td> <td>T85°C</td> <td rowspan="3">-40°C≤Ta≤+60°C</td> <td>Tp≤+80°C</td> </tr> <tr> <td>T100°C</td> <td>Tp≤+95°C</td> </tr> <tr> <td>T120°C</td> <td>Tp≤+115°C</td> </tr> </tbody> </table> <p>Electrical Parameter: Ui=30 V, li=200 mA, Pi=1.0 W, Ci=22 nF, Li=0 mH</p> <p>Intrinsically safe ic Declaration of conformity Applicable standard: EN IEC 60079-0, EN 60079-11</p> <p>Marking: II 3 G Ex ic IIC T5...T4 Gc</p> <p>Ambient and Process temperature</p> <table border="1"> <thead> <tr> <th>Type</th> <th>output</th> <th>Temperature class</th> <th>Ambient Temperature</th> <th>Process Temperature</th> </tr> </thead> <tbody> <tr> <td rowspan="2">Gas</td> <td rowspan="2">-J</td> <td>T5</td> <td>-40°C≤Ta≤+40°C</td> <td>Tp≤+95°C</td> </tr> <tr> <td>T4</td> <td>-40°C≤Ta≤+60°C</td> <td>Tp≤+120°C</td> </tr> </tbody> </table> <p>Electrical Parameter: Ui=42 V, Ci=22 nF, Li=0 mH</p>	Type	output	Temperature class	Ambient temperature	Process temperature	Gas	-J	T5	-55°C≤Ta≤+40°C	Tp≤+95°C	T4	-55°C≤Ta≤+60°C	Tp≤+120°C	Type	output	Maximum surface temperature	Ambient temperature	Process temperature	Dust	-	T85°C	-40°C≤Ta≤+60°C	Tp≤+80°C	T100°C	Tp≤+95°C	T120°C	Tp≤+115°C	Type	output	Temperature class	Ambient Temperature	Process Temperature	Gas	-J	T5	-40°C≤Ta≤+40°C	Tp≤+95°C	T4
Type	output	Temperature class	Ambient temperature	Process temperature																																				
Gas	-J	T5	-55°C≤Ta≤+40°C	Tp≤+95°C																																				
		T4	-55°C≤Ta≤+60°C	Tp≤+120°C																																				
Type	output	Maximum surface temperature	Ambient temperature	Process temperature																																				
Dust	-	T85°C	-40°C≤Ta≤+60°C	Tp≤+80°C																																				
		T100°C		Tp≤+95°C																																				
		T120°C		Tp≤+115°C																																				
Type	output	Temperature class	Ambient Temperature	Process Temperature																																				
Gas	-J	T5	-40°C≤Ta≤+40°C	Tp≤+95°C																																				
		T4	-40°C≤Ta≤+60°C	Tp≤+120°C																																				
		<p>Output signal Code:T PROFINET</p> <p>Certificate: FM25ATEX0009X</p> <p>Applicable standard: EN IEC 60079-0, EN 60079-11, CLC IEC/TS 60079-47</p> <p>Marking: II 1 G Ex ia IIC T5...T4 Ga, II 2 D Ex ia IIIC T85°C...T120°C Db</p> <p>Ambient and Process temperature</p> <table border="1"> <thead> <tr> <th>Type</th> <th>output</th> <th>Temperature class</th> <th>Ambient temperature</th> <th>Process temperature</th> </tr> </thead> <tbody> <tr> <td rowspan="2">Gas</td> <td rowspan="2">-T</td> <td>T5</td> <td>-40°C≤Ta≤+40°C</td> <td>Tp≤+95°C</td> </tr> <tr> <td>T4</td> <td>-40°C≤Ta≤+60°C</td> <td>Tp≤+120°C</td> </tr> </tbody> </table> <table border="1"> <thead> <tr> <th>Type</th> <th>output</th> <th>Maximum surface temperature</th> <th>Ambient temperature</th> <th>Process temperature</th> </tr> </thead> <tbody> <tr> <td rowspan="3">Dust</td> <td rowspan="3">-</td> <td>T85°C</td> <td rowspan="3">-40°C≤Ta≤+60°C</td> <td>Tp≤+80°C</td> </tr> <tr> <td>T100°C</td> <td>Tp≤+95°C</td> </tr> <tr> <td>T120°C</td> <td>Tp≤+115°C</td> </tr> </tbody> </table> <p>Electrical parameter: 2-WISE power load</p>	Type	output	Temperature class	Ambient temperature	Process temperature	Gas	-T	T5	-40°C≤Ta≤+40°C	Tp≤+95°C	T4	-40°C≤Ta≤+60°C	Tp≤+120°C	Type	output	Maximum surface temperature	Ambient temperature	Process temperature	Dust	-	T85°C	-40°C≤Ta≤+60°C	Tp≤+80°C	T100°C	Tp≤+95°C	T120°C	Tp≤+115°C											
Type	output	Temperature class	Ambient temperature	Process temperature																																				
Gas	-T	T5	-40°C≤Ta≤+40°C	Tp≤+95°C																																				
		T4	-40°C≤Ta≤+60°C	Tp≤+120°C																																				
Type	output	Maximum surface temperature	Ambient temperature	Process temperature																																				
Dust	-	T85°C	-40°C≤Ta≤+60°C	Tp≤+80°C																																				
		T100°C		Tp≤+95°C																																				
		T120°C		Tp≤+115°C																																				
	-KU1	Multiple type of protection (KF1 or KS1)																																						

Item	Code	Description																											
IECEX explosion protection	-SF1	IECEX Flameproof Enclosure/ Dust ignition protection by enclosure Certificate: IECEX FMG 25.0002X Applicable standard: IEC 60079-0, IEC 60079-1, IEC 60079-31 Marking: Flameproof Approval: Ex db IIC T6...T4 Gb Dust-Ignitionproof Approval: Ex tb IIC T85°C Db Ambient and Process temperature																											
		<table border="1"> <thead> <tr> <th>Type</th> <th>output</th> <th>Temperature class</th> <th>Ambient Temperature</th> <th>Process Temperature</th> </tr> </thead> <tbody> <tr> <td rowspan="3">Gas</td> <td rowspan="3">-</td> <td>T6</td> <td>-60°C≤Ta≤+75°C</td> <td>-60°C≤Tp≤+80°C</td> </tr> <tr> <td>T5</td> <td>-60°C≤Ta≤+80°C</td> <td>-60°C≤Tp≤+95°C</td> </tr> <tr> <td>T4</td> <td>-60°C≤Ta≤+75°C</td> <td>-60°C≤Tp≤+120°C</td> </tr> </tbody> </table> <table border="1"> <thead> <tr> <th>Type</th> <th>output</th> <th>Maximum surface temperature</th> <th>Ambient temperature</th> <th>Process temperature</th> </tr> </thead> <tbody> <tr> <td>Dust</td> <td>-</td> <td>T85°C</td> <td>-40°C≤Ta≤+75°C</td> <td>-40°C≤Tp≤+80°C</td> </tr> </tbody> </table>	Type	output	Temperature class	Ambient Temperature	Process Temperature	Gas	-	T6	-60°C≤Ta≤+75°C	-60°C≤Tp≤+80°C	T5	-60°C≤Ta≤+80°C	-60°C≤Tp≤+95°C	T4	-60°C≤Ta≤+75°C	-60°C≤Tp≤+120°C	Type	output	Maximum surface temperature	Ambient temperature	Process temperature	Dust	-	T85°C	-40°C≤Ta≤+75°C	-40°C≤Tp≤+80°C	
Type	output	Temperature class	Ambient Temperature	Process Temperature																									
Gas	-	T6	-60°C≤Ta≤+75°C	-60°C≤Tp≤+80°C																									
		T5	-60°C≤Ta≤+80°C	-60°C≤Tp≤+95°C																									
		T4	-60°C≤Ta≤+75°C	-60°C≤Tp≤+120°C																									
Type	output	Maximum surface temperature	Ambient temperature	Process temperature																									
Dust	-	T85°C	-40°C≤Ta≤+75°C	-40°C≤Tp≤+80°C																									
	-SS1	IECEX Intrinsically safe Output signal Code:J HART Intrinsically safe ia Certificate: IECEX FMG 25.0002X Applicable standard: IEC 60079-0, IEC 60079-11 Marking: Ex ia IIC T5...T4 Ga, Ex ia IIIC T85°C...T120°C Db Ambient and Process temperature																											
		<table border="1"> <thead> <tr> <th>Type</th> <th>output</th> <th>Temperature class</th> <th>Ambient temperature</th> <th>Process temperature</th> </tr> </thead> <tbody> <tr> <td rowspan="2">Gas</td> <td rowspan="2">-J</td> <td>T5</td> <td>-55°C≤Ta≤+40°C</td> <td>Tp≤+95°C</td> </tr> <tr> <td>T4</td> <td>-55°C≤Ta≤+60°C</td> <td>Tp≤+120°C</td> </tr> </tbody> </table> <table border="1"> <thead> <tr> <th>Type</th> <th>output</th> <th>Maximum surface temperature</th> <th>Ambient temperature</th> <th>Process temperature</th> </tr> </thead> <tbody> <tr> <td rowspan="3">Dust</td> <td rowspan="3">-</td> <td>T85°C</td> <td rowspan="3">-40°C≤Ta≤+60°C</td> <td>Tp≤+80°C</td> </tr> <tr> <td>T100°C</td> <td>Tp≤+95°C</td> </tr> <tr> <td>T120°C</td> <td>Tp≤+115°C</td> </tr> </tbody> </table> Electrical Parameter: Ui=30 V, Ii=200 mA, Pi=1.0 W, Ci=22 nF, Li=0 mH Intrinsically safe ic Certificate: IECEX FMG 25.0002X Applicable standard: IEC 60079-0, IEC 60079-11 Marking: Ex ic IIC T5...T4 Gc Ambient and Process temperature	Type	output	Temperature class	Ambient temperature	Process temperature	Gas	-J	T5	-55°C≤Ta≤+40°C	Tp≤+95°C	T4	-55°C≤Ta≤+60°C	Tp≤+120°C	Type	output	Maximum surface temperature	Ambient temperature	Process temperature	Dust	-	T85°C	-40°C≤Ta≤+60°C	Tp≤+80°C	T100°C	Tp≤+95°C	T120°C	Tp≤+115°C
Type	output	Temperature class	Ambient temperature	Process temperature																									
Gas	-J	T5	-55°C≤Ta≤+40°C	Tp≤+95°C																									
		T4	-55°C≤Ta≤+60°C	Tp≤+120°C																									
Type	output	Maximum surface temperature	Ambient temperature	Process temperature																									
Dust	-	T85°C	-40°C≤Ta≤+60°C	Tp≤+80°C																									
		T100°C		Tp≤+95°C																									
		T120°C		Tp≤+115°C																									
		<table border="1"> <thead> <tr> <th>Type</th> <th>output</th> <th>Temperature class</th> <th>Ambient temperature</th> <th>Process temperature</th> </tr> </thead> <tbody> <tr> <td rowspan="2">Gas</td> <td rowspan="2">-J</td> <td>T5</td> <td>-40°C≤Ta≤+40°C</td> <td>Tp≤+95°C</td> </tr> <tr> <td>T4</td> <td>-40°C≤Ta≤+60°C</td> <td>Tp≤+120°C</td> </tr> </tbody> </table> Electrical Parameter: Ui=42 V, Ci=22 nF, Li=0 mH	Type	output	Temperature class	Ambient temperature	Process temperature	Gas	-J	T5	-40°C≤Ta≤+40°C	Tp≤+95°C	T4	-40°C≤Ta≤+60°C	Tp≤+120°C														
Type	output	Temperature class	Ambient temperature	Process temperature																									
Gas	-J	T5	-40°C≤Ta≤+40°C	Tp≤+95°C																									
		T4	-40°C≤Ta≤+60°C	Tp≤+120°C																									

Item	Code	Description																													
IECEx explosion protection	-SS1	Output signal Code:T PROFINET	Certificate: IECEx FMG 25.0002X Applicable standard: IEC 60079-0, IEC 60079-11, IEC TS 60079-47 Marking: Ex ia IIC T5...T4 Ga, Ex ia IIIC T85°C...T120°C Db Ambient and Process temperature <table border="1"> <thead> <tr> <th>Type</th> <th>output</th> <th>Temperature class</th> <th>Ambient temperature</th> <th>Process temperature</th> </tr> </thead> <tbody> <tr> <td rowspan="2">Gas</td> <td rowspan="2">-T</td> <td>T5</td> <td>-40°C≤Ta≤+40°C</td> <td>Tp≤+95°C</td> </tr> <tr> <td>T4</td> <td>-40°C≤Ta≤+60°C</td> <td>Tp≤+120°C</td> </tr> </tbody> </table> <table border="1"> <thead> <tr> <th>Type</th> <th>output</th> <th>Maximum surface temperature</th> <th>Ambient temperature</th> <th>Process temperature</th> </tr> </thead> <tbody> <tr> <td rowspan="3">Dust</td> <td rowspan="3">-</td> <td>T85°C</td> <td rowspan="3">-40°C≤Ta≤+60°C</td> <td>Tp≤+80°C</td> </tr> <tr> <td>T100°C</td> <td>Tp≤+95°C</td> </tr> <tr> <td>T120°C</td> <td>Tp≤+115°C</td> </tr> </tbody> </table> Electrical parameter: 2-WISE power load		Type	output	Temperature class	Ambient temperature	Process temperature	Gas	-T	T5	-40°C≤Ta≤+40°C	Tp≤+95°C	T4	-40°C≤Ta≤+60°C	Tp≤+120°C	Type	output	Maximum surface temperature	Ambient temperature	Process temperature	Dust	-	T85°C	-40°C≤Ta≤+60°C	Tp≤+80°C	T100°C	Tp≤+95°C	T120°C	Tp≤+115°C
	Type	output	Temperature class	Ambient temperature	Process temperature																										
Gas	-T	T5	-40°C≤Ta≤+40°C	Tp≤+95°C																											
		T4	-40°C≤Ta≤+60°C	Tp≤+120°C																											
Type	output	Maximum surface temperature	Ambient temperature	Process temperature																											
Dust	-	T85°C	-40°C≤Ta≤+60°C	Tp≤+80°C																											
		T100°C		Tp≤+95°C																											
		T120°C		Tp≤+115°C																											
-SU1	Multiple type of protection (SF1 or SS1)																														
Combination of Approval	-VU1	Combination of KU1, FU1, CU1 and SU1																													

< Ordering Information >

1. Model, suffix codes, and option codes
2. Calibration range, unit and output mode
 - 1) Calibration range can be specified with range value specifications up to 5 digits (excluding any decimal point) for low or high range limits within the range of -99999 to 99999. When reverse range is designated, specify Lower Range Value (LRV) as greater than Upper Range Value (URV)
 - 2) Specify only one unit from the table, 'Factory Settings' when shipped.
 - 3) Specify output mode from LINEAR or SQUARE ROOT. When SQUARE ROOT is selected, the smaller value of the range limit must be zero.
3. Display scale, unit and display mode (for transmitters equipped with Display only)
 Specify either 0 to 100 % or unit scale and 'Range and Unit' for units scale: Scale range can be specified with range limit specifications up to 5 digits (excluding any decimal point) for low or high range limits within the range of -99999 to 99999. The unit display consists of 6-digit, therefore, if the specified unit is longer than 7 characters excluding '/', the first 6 characters will be displayed on the unit display.
 Select either LINEAR or SQRT for the display mode.
 For PROFINET communication, select from the display unit options and select LINEAR when the output mode is LINEAR, and select SQRT when the output mode is SQUARE ROOT.
 When SQUARE ROOT is selected for display mode, the smaller value of the scale limit must be zero.
4. TAG NO (if required)
5. Parameter Setting (Optional code /CB, /CA, /CK, /CJ)
 - Software damping in second (0.00 to 100.00)
 - Descriptor (up to 16 characters)
 - Message (Optional code: /CA and /CJ): up to 32 characters
 - Memo (Optional code /CB and /CK) up to 32 character
6. Burnout direction setting (for HART protocol) High or Low
7. Network setting (for PROFINET protocol)
 Specify the IP ADDRESS, SUBNET MASK, DEFAULT GATEWAY, and STATION NAME.
 If you specify it, please specify a combination of settings that can be communicated.

< Factory Setting >

Tag number. (*1)	As specified in order: up to 22 characters (SOFTWARE TAG: up to 32 characters)	
Software damping	2.00 s or as specified in order	
Output mode	'Linear' unless otherwise specified in order	
Calibration range lower range value	As specified in order	
Calibration range upper range value	As specified in order	
Calibration range units	Selected from mmH ₂ O, mmH ₂ O(68°F), mmAq(*2), mmWG(*2), mmHg, Pa, hPa, kPa, MPa, mbar, bar, gf/cm ² , kgf/cm ² , inH ₂ O, inH ₂ O(68°F), inHg, ftH ₂ O, ftH ₂ O(68°F) or psi. (Only one unit can be specified)	
Display setting	Designated value specified in order. (% , or user scaled value.) Display mode 'Linear' or 'Square root' is also as specified in order	
Static pressure display range	Capsule range code M, J, P, H, K, Q, V	0 to 25 MPa, absolute value. Measuring high pressure side.
	Low flow type or Capsule range code F, L or Wetted material code H, M, T, A, D, M, B, W	0 to 16 MPa, absolute value. Measuring high pressure side.
	Capsule range code: 1, 2, 3, 5, 6	0 to 32 MPa, absolute value. Measuring high pressure side.
Burnout (for HART protocol)	'High' unless otherwise specified in order	
Network setting (for PROFINET protocol)	Unless otherwise specified, - IP ADDRESS: 192.168.1.210 - SUBNET MASK: 255.255.255.0 - DEFAULT GATEWAY: 0.0.0.0 - STATION NAME: pressure-transmitter-ejx-s (*3)	

*1: The specified characters will be engraved on the tag plate and written into the main unit (communication parameters) before shipping.
 If you want to specify characters different from the tag plate, please specify it separately in the software tag.
 Available characters include uppercase and lowercase letters, numbers, spaces, and the following symbols.

!	#	()	+	-	.	/	:	=	_
---	---	---	---	---	---	---	---	---	---	---

For HART communication type, the tag parameter will be written using the first 8 characters. If lowercase letters are included, they will be converted to uppercase.

*2: Not available for HART protocol type.

*3: The STATION NAME can be a combination of lowercase letters, numbers, and hyphens, up to 40 characters long.

< Related Instruments >

FieldMate Versatile Device Management Wizard: Refer to GS 01R01A01-01E.

< Reference >

1. FieldMate; Trademark of Yokogawa Electric Corporation.
2. Hastelloy; Trademark of Haynes International Inc.
3. HART®: Registered trademark of the FieldComm Group.

Other company names and product names used in this material are registered trademarks or trademarks of their respective owners.

< Information on EU WEEE Directive >

EU WEEE (Waste Electrical and Electronic Equipment) Directive is only valid in the EU.

This instrument is intended to be sold and used only as a part of equipment which is excluded from WEEE Directive, such as large-scale stationary industrial tools, a large-scale fixed installation and so on, and, therefore, subjected to the exclusion from the scope of the WEEE Directive. The instrument should be disposed of in accordance with local and national legislation/regulations.